

AC SERVO SYSTEMS

SANMOTION G

200 VAC 30 W to 1.5 kW
100 VAC 30 to 200 W

AC servo systems

Ver. 1.1
English



SANMOTION G

AC SERVO SYSTEMS

Next-Level Servo System That
Combines Powerful Performance and
User-Friendliness



Servo Motors

Lineup

200 V class

Low-inertia models: 40 to 100 mm sq., 50 W to 1.5 kW

Medium-inertia models: 40 to 130 mm sq., 30 W to 1.5 kW

100 V class

Low-inertia models: 40 to 60 mm sq., 50 to 200 W

Medium-inertia models: 40 to 60 mm sq., 30 to 200 W

Motor length up to
22% shorter

High-resolution
encoder up to
27-bit

Max. speed
6500 min⁻¹

Newly developed holding
brake with increased
reliability

Servo Amplifiers

Lineup

Analog/Pulse

EtherCAT

200 V class: 10, 20, 30, 50 A

100 V class: 10, 20, 30 A

Speed frequency response
3.5 kHz
(1.6 times higher)

Positioning settling time
shortened to
1/3

System status monitoring and
preventive maintenance
with various
diagnostic functions

Advanced tuning to
automatically adjust
to optimal parameters



Contents

Features	p. 4
Lineup	p. 11
Standard Model Number List	p. 12
Servo Motors	p. 17
Specifications and Dimensions	p. 18
Linear Servo Motors	p. 43
Specifications and Dimensions	p. 44
Servo Amplifiers	
Analog/Pulse Input Type	p. 49
EtherCAT Interface Type	p. 57
Options	p. 63
Replacement Models of Conventional Products	p. 70
Selection Guide	p. 72
Standards Conformity	p. 75
Motor Protection Rating	p. 76
Safety Precautions	p. 77

The Servo System That Delivers What Customers Desire

Want high-precision, stable positioning

This product comes with a **23-bit** encoder as standard (64 times that of our conventional model*), and even an encoder with a maximum of 27-bit high resolution can be selected as an option. The high-resolution encoder enables high-precision and stable positioning.

Conventional stop position

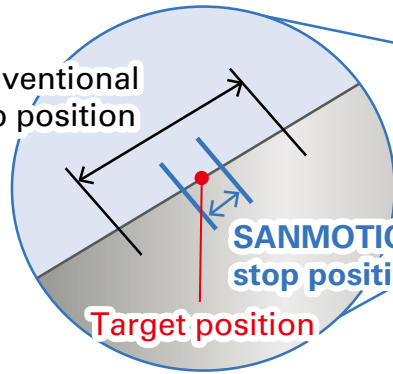

SANMOTION G's stop position

Target position

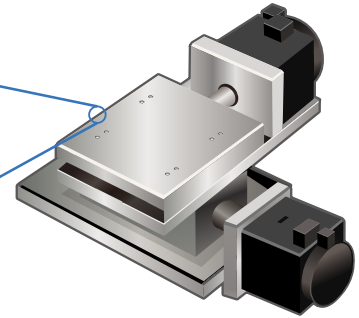

Conventional product*
17-bit: 131,072 P/R

SANMOTION G
23-bit: 8,388,608 P/R
27-bit: 134,217,728 P/R

Want to improve processing quality with high-response control

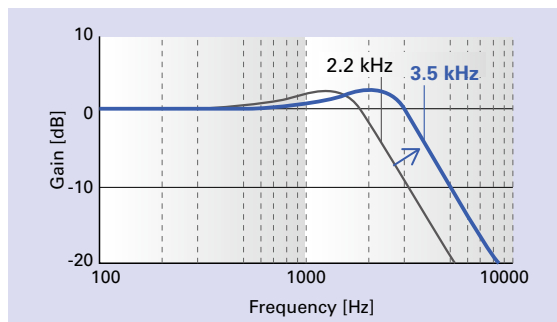

Increased processing quality

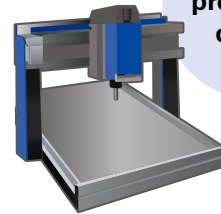

With newly developed current control, speed frequency response has been increased to **3.5 kHz** (1.6 times higher than our conventional product*).

This helps improve the processing quality of machinery.

Need a quick positioning

By accurately detecting and compensating for Coulomb friction, viscous friction, and the force of gravity, the positioning settling time has been made **1/3** that of our conventional product.*

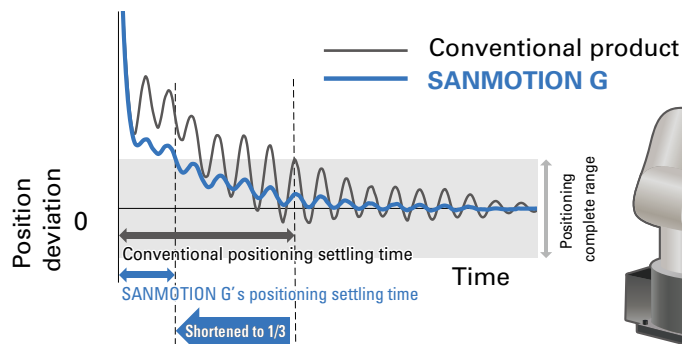

Quick positioning

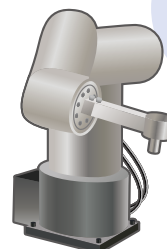

* Conventional product: SANMOTION R AC servo systems

Want a faster motor without size increase

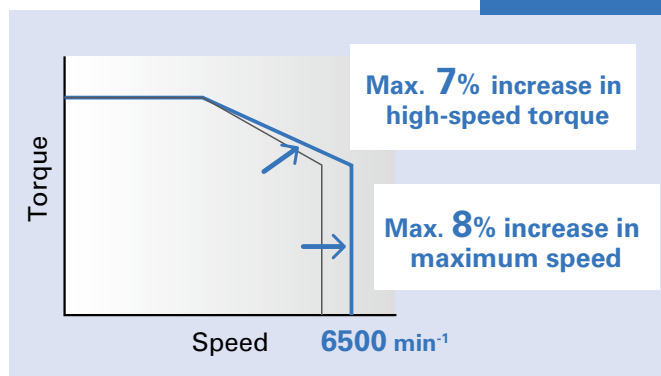

Faster motor speed while maintaining the motor size and precision, which is essential for robots

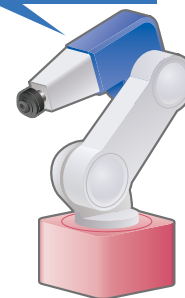

The servo motor's maximum speed has been increased from 6000 min⁻¹ to **6500 min⁻¹** compared to our conventional product.* Also, the new PWM control has increased the peak torque at high speeds by approximately 7%, expanding the motor output range by up to 15%.

This enables the equipment to speed up without using a larger motor while achieving low cogging and low heat generation as well.

Want to make your equipment smaller and lighter



By optimizing the electromagnetic field and the brake structure, the motor length and mass have been reduced compared to our conventional product.*

Motor length	Without brake: 12.2% shorter
	With brake : 11.9% shorter
Motor mass	Without brake: 10.5% lighter
	With brake : 11.4% lighter

The average value of all low- and medium-inertia servo motor models

With optimized thermal design and smaller components used, the servo amplifier has been made 5% lighter than the conventional product.*

Want to make your system more efficient

Compared to our conventional product,* power consumption of servo motors and holding brakes has been reduced by up to **8.4%** and **44%**, respectively. The servo amplifier's power loss has been reduced by up to **26%** in the main circuit thanks to the latest power device used and up to **16%** in the control circuit thanks to a high-efficiency LSI (large-scale integrated) circuit.



* Conventional product: SANMOTION R AC servo systems

Want equipment startup to be faster

This product is equipped with the **advanced tuning** that ensures automatic tuning of parameters by precisely measuring resonance, friction, and load inertia of mechanical systems.

Servo gain and filter can be **automatically adjusted** to stabilize operation and shorten the settling time based on the results of frequency characteristic measurement, which is **11 times more accurate** than the conventional product.*

Startup time of equipment can be shortened and its performance can be increased.

Automatic calculation of the overshoot value and settling time

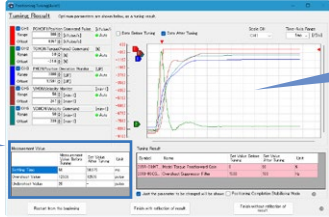

Displays measurement waveforms

Want to enhance monitoring to prevent failures

Failure of holding brake and electronic components can be prevented by **predicting the remaining life of the holding brake**, in systems where braking is needed, and by **optimally controlling the inrush current limiting circuit**.

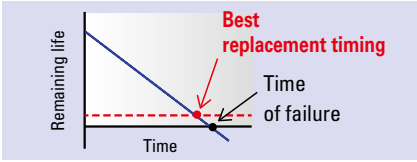

The monitoring of the main circuit input voltage and the detection of overvoltage in the control circuit power supply can be performed. Early identification of faults can help **shorten system downtime**.

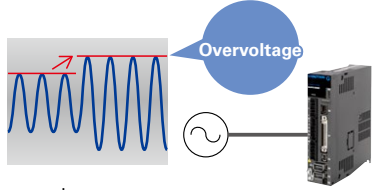

The quality of encoder and EtherCAT communication can be diagnosed. The impact on communication quality due to noise and installation environments can be monitored, contributing to improving the **environmental durability** of the system.

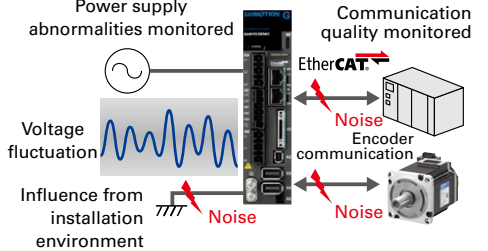

Want to replace your current system without a hassle

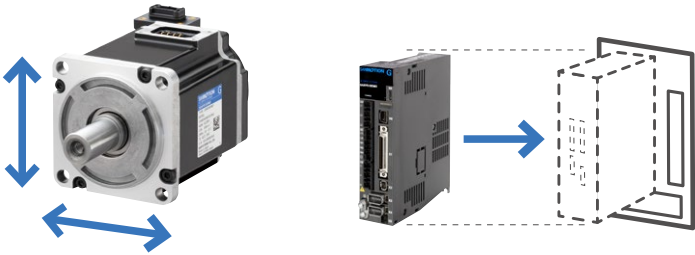

With the motor flange size, output shaft shape, amplifier dimensions, mounting, interface, and functionality fully compatible with our conventional SANMOTION R series, **replacement can be done smoothly**.

* Conventional product: SANMOTION R AC servo systems

Want to use equipment at high temperatures and high altitudes

Compared to the conventional product,* **the operating temperature range and operating altitude have been expanded**, enabling use in severe environments in various regions.

Operating temperature range (Servo amplifiers)

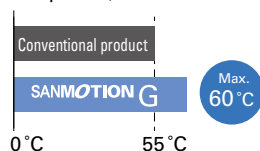

Operating altitude (Servo amplifiers and servo motors)

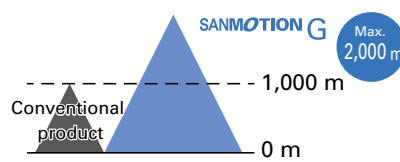

Note: Output values might be derated.

Want to use for equipment with vibration

Compared to the conventional product,* the **vibration resistance** of the servo amplifier and servo motor have been increased approximately **20%** and **2 times**, respectively. This makes it even more suitable for equipment with high levels of vibration such as CT scanners and press machines.

Vibration resistance

4.9 m/s²
→ **6.0 m/s²**

24.5 m/s²
→ **50.0 m/s²**

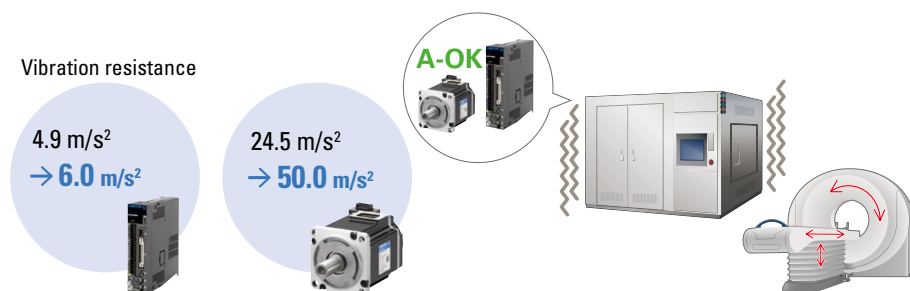

Want to simplify cable connection

40 to 86 mm sq. servo motors use a connector that **integrates power and brake connections**. This reduces the number of parts and makes wiring easier. 100 to 130 mm sq. servo motors use press-lock connectors for easy wiring.

Power and brake connections integrated into one:
3 cables → 2 cables

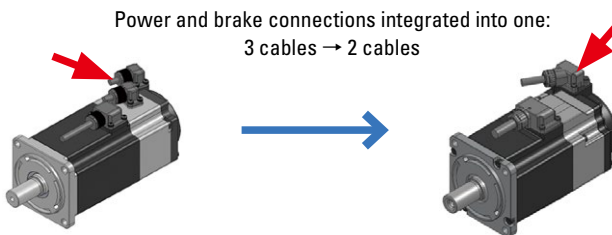

Want to increase the holding brake reliability

The newly developed holding brake features enhanced environmental resistance, and the holding torque does not decrease even at high temperatures and high humidity. This is a **safe and reliable brake** that causes little wear on the friction material even when the motor idles or brakes abruptly.

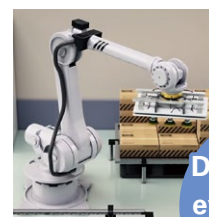

Does not fall even at high temperatures

* Conventional product: SANMOTION R AC servo systems

Want to smoothly switch from position control to torque control

Control modes can be **switched smoothly in real time**.

This improves shock mitigation during control modes switching (from position control to torque control) and controllability during pressing.

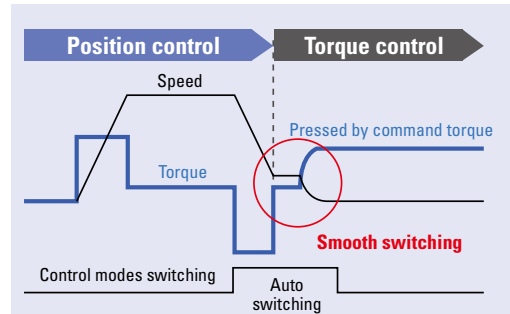
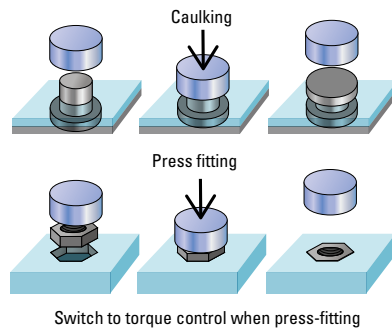

Want to monitor servo amplifier status

The amplifier status is visually displayed on the PC screen, allowing user to intuitively check the status.

Axis selection

1	Axis1	2	Axis2
<input type="checkbox"/>	S-ON	<input type="checkbox"/>	S-OFF
<input type="checkbox"/>	ALM	<input type="checkbox"/>	ALM95

Servo ON / Alarm status display

I/O settings and status display

GPIO monitor

OUT1	The output is ON while motor excitation	Invalid
OUT2	The output is ON while power supply ON	Valid

Want to save test run settings

The new software will provide expanded setting retention functions for test runs while maintaining the operability of the existing setup software, SANMOTION MOTOR SETUP SOFTWARE.

Jog operation

Operative Conditions

Feeding velocity: 1000 [min-1] (0 - 65535) [Edit]

JOG Acc./Dec. Time Constant: 100 [msec] (0 - 18000) [Decision]

JOG Torque/Force Command Limit: 500.0 [N] (10 - 500) [Cancel]

Positioning operation

No	Direction	Feeding velocity [min-1]	Accel/Decel time [ms]	Torque limit value [N]	Number of positioning pulses [pulse]	Rest time [ms]
1	Positive	1000	100	120.0	0	1000

Store and manage test run operation settings in a project file

Want to create a system that conforms to safety standards

It complies with **ISO 13849-1 (Cat3, PL=e)** and **IEC 61508 (SIL3)**, making it easy to build safety systems for equipment.

It also complies with various regulations required to obtain safety standards for equipment.

(For the compliance with safety standards of linear servo motors, contact us for details)



For servo amplifiers only

Water and dust protection

Our servo motors are highly resistant to water and dust ingress with an IP67 rating, ensuring normal operation even in severe environments.

IP **6** **7**

Protection against dust		Protection against water	
6	Complete protection against dust	7	Protection against temporary immersion in water

Protection does not cover the shaft seal part. Protection rating is for when connectors are mounted.

Compact and high-thrust linear servo motors

Linear servo motors with direct, straight-line drive and high thrust are available.



EtherCAT communication

EtherCAT is a 100 Mbps high-speed fieldbus system. It contributes to shortening machine cycle time. This highly versatile EtherCAT is compatible with Ethernet, which makes it possible to build a system where various machines co-exist. Also, the EtherCAT conformance test certificate from a trusted third party has been acquired.

EtherCAT® is a registered trademark and patented technology, licensed by Beckhoff Automation GmbH, Germany.



Fully closed-loop control

A fully closed-loop control is possible by using information from two encoders: e.g., a linear encoder mounted on the load machine and a high-resolution motor-mounted encoder. This achieves high responsiveness even when the motor axis and load are highly skewed.

High-precision battery-less absolute encoder

Our servo motors come with a high-precision battery-less absolute encoder as standard.

It does not use batteries, which require periodic replacement, eliminating cumbersome maintenance work and export procedures.

We offer various encoders that help select the best encoder for your machine. See the table below.

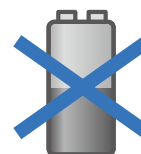

No need to concern about battery life or export procedures

Type (Encoder model no. in parentheses)	Standard				Customization
	Single-turn resolution	Multi-turn resolution	Baud rate	Absolute angular accuracy	
Battery-less absolute encoder (Model No. GAER) This is a high-precision battery-less optical multi-turn encoder. It reduces maintenance because it doesn't need batteries, which require maintenance.	8388608 (23-bit)	65536 (16-bit)	4.0 Mbps	Approx. 0.167°	<ul style="list-style-type: none"> Single-turn resolution: 131072 (17-bit), 1048576 (20-bit), 134217728 (27-bit) Baud rate: 2.5 Mbps Absolute angular accuracy: Under 0.0167°
Single-turn absolute encoder (Model No. GAEN) This is a thin profile, optical single-turn encoder. It achieves wire saving particularly for systems that currently use incremental encoders, and helps downsize the systems.	8388608 (23-bit)	–	4.0 Mbps	Approx. 0.167°	<ul style="list-style-type: none"> Single-turn resolution: 131072 (17-bit), 1048576 (20-bit), 134217728 (27-bit) Baud rate: 2.5 Mbps Absolute angular accuracy: Under 0.0167°

Contact us for more information on other encoders.

Application Examples

In semiconductor factories
CMP equipment
 Used for polishing and flattening semiconductor wafers

(chemical mechanical polishing equipment)

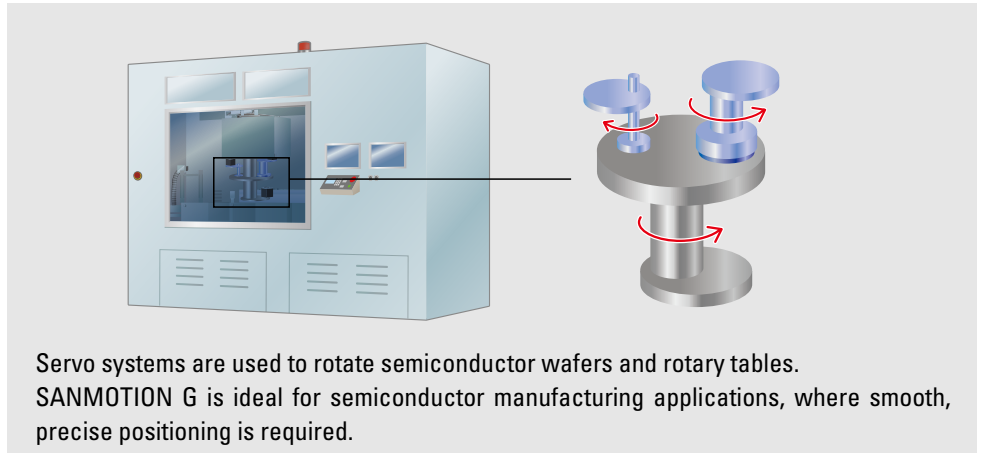

Servo systems are used to rotate semiconductor wafers and rotary tables. SANMOTION G is ideal for semiconductor manufacturing applications, where smooth, precise positioning is required.

In semiconductor factories
Overhead conveyor
 Automatic conveyor equipment that is suspended from and moves along the guide rails installed overhead

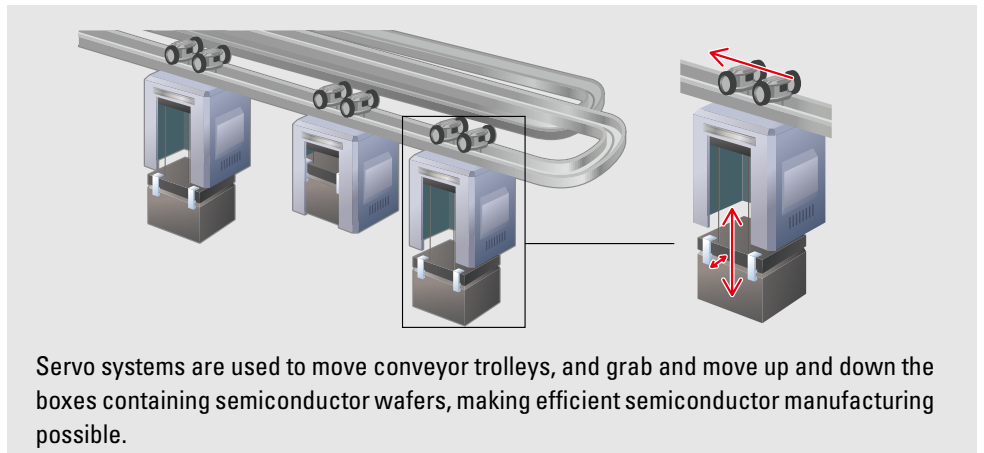

Servo systems are used to move conveyor trolleys, and grab and move up and down the boxes containing semiconductor wafers, making efficient semiconductor manufacturing possible.

In food/beverage factories
Filling machine
 Used to fill containers with liquids

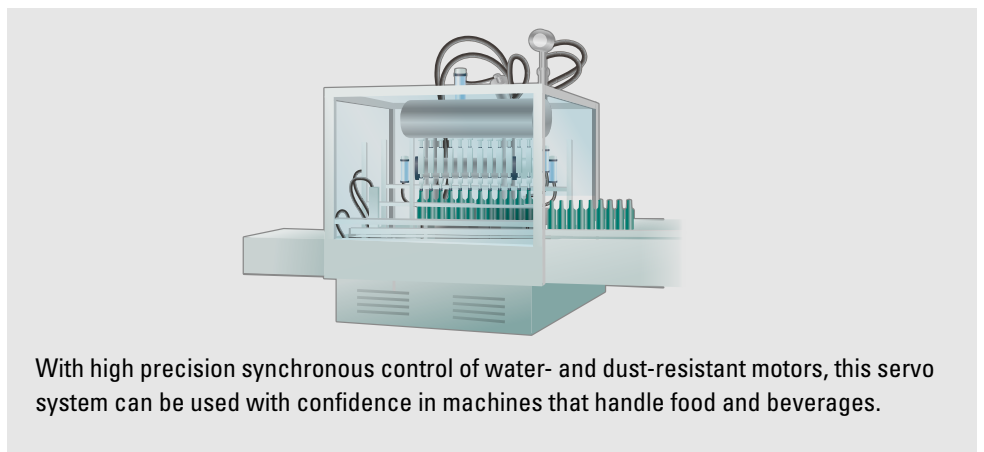

With high precision synchronous control of water- and dust-resistant motors, this servo system can be used with confidence in machines that handle food and beverages.

In hospitals
CT scanner
 Used to perform a scan of a patient to create cross-sectional images of the body by using a rotating X-ray tube and a row of detectors

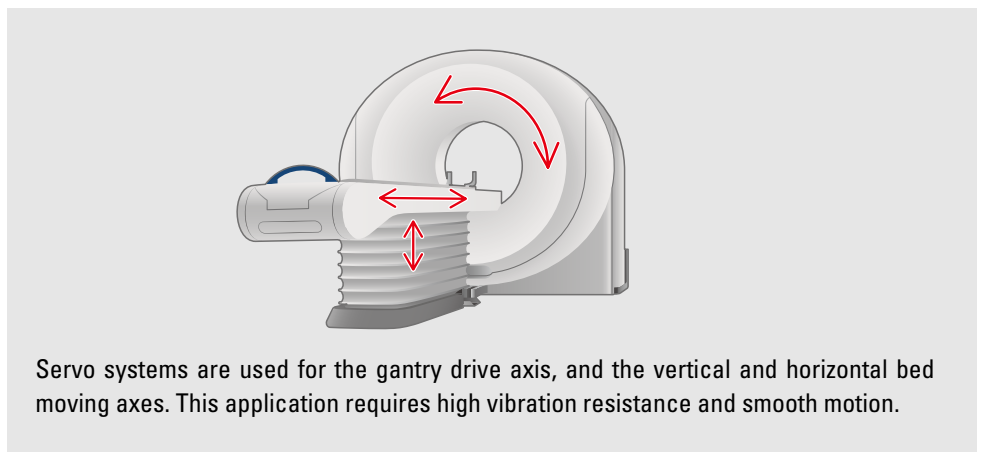

Servo systems are used for the gantry drive axis, and the vertical and horizontal bed moving axes. This application requires high vibration resistance and smooth motion.

Lineup

Servo motor	Input voltage	Flange size [mm]	Rated output [kW]
Low-inertia servo motor These motors feature high-acceleration drive and high torque even at high speeds. They are suitable for injection molding machines and general industrial machinery.	200 V	40 sq.	0.05 0.1 0.15
		60 sq.	0.2 0.4 0.6
		80 sq.	0.75 1
		100 sq.	1 1.5
	100 V	40 sq.	0.05 0.1
		60 sq.	0.2

Medium-inertia servo motor These motors feature compact size, light weight, and high efficiency. These are ideal for robots, injection molding machines, and industrial machines.	200 V	40 sq.	0.03 0.05 0.1 0.15
		60 sq.	0.1 0.2 0.4 0.6
		80 sq.	0.2 0.4 0.75 1
		86 sq.	0.75 1
		100 sq.	0.75 1 1.5
		130 sq.	0.55 1.2
	100 V	40 sq.	0.03 0.05 0.1
		60 sq.	0.1 0.2

Linear servo motor	Input voltage	Rated thrust [N]
Flat type with core	200 V	140 200 260 310 340
Center magnet type with core	200 V	350

Servo amplifier	Features	Amplifier capacity [A]	Compatible servo motor rated output [kW]
Analog/Pulse	This servo amplifier can enhance the value of combined equipment by increasing responsiveness and ensuring safety with a variety of safety functions. This general-purpose interface enables torque/speed control by analog voltage command and position control by pulse command.	200 VAC class 10, 20, 30, 50	0.03 to 1.5
		100 VAC class 10, 20, 30	0.03 to 0.2
EtherCAT	EtherCAT, a high-speed fieldbus, is an open network with high versatility and widely used with high-precision industrial equipment. It can be used in combination with our SANMOTION C motion controller. For more information, see the SANMOTION C catalog.	200 VAC class 10, 20, 30, 50	0.03 to 1.5
		100 VAC class 10, 20, 30	0.03 to 0.2

Standard Model Number List

Contact us for specifications of models that are not listed.

200 V

Low-inertia Servo Motor

Standard specifications... Ingress protection: IP67, standards conformity: UL, cUL, CE, UKCA

Motor flange size	Rated output	Model no.				Page	Compatible servo amplifier capacity
		Battery-less absolute encoder		Single-turn absolute encoder			
		Without holding brake	With holding brake	Without holding brake	With holding brake		
40 mm sq.	50 W	GAM1A4005F0XRK□	GAM1A4005F0CRK□	GAM1A4005F0XNK□	GAM1A4005F0CNK□	p. 18	10 A
	100 W	GAM1A4010F0XRK□	GAM1A4010F0CRK□	GAM1A4010F0XNK□	GAM1A4010F0CNK□	p. 18	10 A
	150 W	GAM1A4015F0XRK□	GAM1A4015F0CRK□	GAM1A4015F0XNK□	GAM1A4015F0CNK□	p. 18	20 A
60 mm sq.	200 W	GAM1A6020F0XRK□	GAM1A6020F0CRK□	GAM1A6020F0XNK□	GAM1A6020F0CNK□	p. 20	20 A
	400 W	GAM1A6040F0XRK□	GAM1A6040F0CRK□	GAM1A6040F0XNK□	GAM1A6040F0CNK□	p. 20	20 A
	600 W	GAM1A6060F0XRK□	GAM1A6060F0CRK□	GAM1A6060F0XNK□	GAM1A6060F0CNK□	p. 20	50 A
80 mm sq.	750 W	GAM1A8075V0XRK□	GAM1A8075V0CRK□	GAM1A8075V0XNK□	GAM1A8075V0CNK□	p. 22	30 A
		GAM1A8075F0XRK□	GAM1A8075F0CRK□	GAM1A8075F0XNK□	GAM1A8075F0CNK□	p. 22	50 A
	1 kW	GAM1A8100F0XRK□	GAM1A8100F0CRK□	GAM1A8100F0XNK□	GAM1A8100F0CNK□	p. 22	50 A
100 mm sq.	1 kW	GAM1AA100H0XRK□*	GAM1AA100H0CRK□*	GAM1AA100H0XNK□*	GAM1AA100H0CNK□*	p. 24	30 A
		GAM1AA100F0XRK□	GAM1AA100F0CRK□	GAM1AA100F0XNK□	GAM1AA100F0CNK□	p. 24	50 A
	1.5 kW	GAM1AA150H0XRK□*	GAM1AA150H0CRK□*	GAM1AA150H0XNK□*	GAM1AA150H0CNK□*	p. 24	30 A
		GAM1AA150F0XRK□	GAM1AA150F0CRK□	GAM1AA150F0XNK□	GAM1AA150F0CNK□	p. 24	50 A

Note: The □ symbol in the model number denotes the following:

- 0: Circular shaft (without key) without oil seal
- 1: Circular shaft (without key) with oil seal
- 2: Keyway shaft without oil seal
- 3: Keyway shaft with oil seal

The motor outputs may be derated to 90 to 95% of the rated values due to the combined brake and oil seal.

* GAM1AA100H0, GAM1AA150H0...When using a single-phase input power supply for the servo amplifier, make sure that the servo motor output is 750 W or less by adjusting the torque and speed.

Standard specifications... Ingress protection: IP67, standards conformity: UL, cUL, CE, UKCA

Motor flange size	Rated output	Model no.				Page	Compatible servo amplifier capacity
		Battery-less absolute encoder		Single-turn absolute encoder			
		Without holding brake	With holding brake	Without holding brake	With holding brake		
40 mm sq.	30 W	GAM2A4003F0XRK□	GAM2A4003F0CRK□	GAM2A4003F0XNK□	GAM2A4003F0CNK□	p. 28	10 A
	50 W	GAM2A4005F0XRK□	GAM2A4005F0CRK□	GAM2A4005F0XNK□	GAM2A4005F0CNK□	p. 28	10 A
	100 W	GAM2A4010F0XRK□	GAM2A4010F0CRK□	GAM2A4010F0XNK□	GAM2A4010F0CNK□	p. 28	10 A
	150 W	GAM2A4015V0XRK□	GAM2A4015V0CRK□	GAM2A4015V0XNK□	GAM2A4015V0CNK□	p. 28	10 A
		GAM2A4015F0XRK□	GAM2A4015F0CRK□	GAM2A4015F0XNK□	GAM2A4015F0CNK□	p. 28	20 A
60 mm sq.	100 W	GAM2A6010F0XRK□	GAM2A6010F0CRK□	GAM2A6010F0XNK□	GAM2A6010F0CNK□	p. 30	10 A
	200 W	GAM2A6020F0XRK□	GAM2A6020F0CRK□	GAM2A6020F0XNK□	GAM2A6020F0CNK□	p. 30	20 A
	400 W	GAM2A6040F0XRK□	GAM2A6040F0CRK□	GAM2A6040F0XNK□	GAM2A6040F0CNK□	p. 30	20 A
	600 W	GAM2A6060V0XRK□	GAM2A6060V0CRK□	GAM2A6060V0XNK□	GAM2A6060V0CNK□	p. 30	30 A
		GAM2A6060F0XRK□	GAM2A6060F0CRK□	GAM2A6060F0XNK□	GAM2A6060F0CNK□	p. 30	50 A
80 mm sq.	200 W	GAM2A8020F0XRK□	GAM2A8020F0CRK□	GAM2A8020F0XNK□	GAM2A8020F0CNK□	p. 32	20 A
	400 W	GAM2A8040F0XRK□	GAM2A8040F0CRK□	GAM2A8040F0XNK□	GAM2A8040F0CNK□	p. 32	20 A
	750 W	GAM2A8075V0XRK□	GAM2A8075V0CRK□	GAM2A8075V0XNK□	GAM2A8075V0CNK□	p. 32	30 A
		GAM2A8075F0XRK□	GAM2A8075F0CRK□	GAM2A8075F0XNK□	GAM2A8075F0CNK□	p. 32	50 A
	1 kW	GAM2A8100F0XRK□	GAM2A8100F0CRK□	GAM2A8100F0XNK□	GAM2A8100F0CNK□	p. 32	50 A
86 mm sq.	750 W	GAM2A9075F0XRK□	GAM2A9075F0CRK□	GAM2A9075F0XNK□	GAM2A9075F0CNK□	p. 34	50 A
	1 kW	GAM2A9100H0XRK□*	GAM2A9100H0CRK□*	GAM2A9100H0XNK□*	GAM2A9100H0CNK□*	p. 34	30 A
		GAM2A9100F0XRK□	GAM2A9100F0CRK□	GAM2A9100F0XNK□	GAM2A9100F0CNK□	p. 34	50 A
100 mm sq.	750 W	GAM2AA075F0XRK□	GAM2AA075F0CRK□	GAM2AA075F0XNK□	GAM2AA075F0CNK□	p. 36	30 A
	1 kW	GAM2AA100F0XRK□	GAM2AA100F0CRK□	GAM2AA100F0XNK□	GAM2AA100F0CNK□	p. 36	50 A
	1.5 kW	GAM2AA150H0XRK□	GAM2AA150H0CRK□	GAM2AA150H0XNK□	GAM2AA150H0CNK□	p. 36	50 A
		GAM2AA150F0XRK□	GAM2AA150F0CRK□	GAM2AA150F0XNK□	GAM2AA150F0CNK□	p. 36	50 A
130 mm sq.	550 W	GAM2AB055D0XRK□	GAM2AB055D0CRK□	GAM2AB055D0XNK□	GAM2AB055D0CNK□	p. 38	30 A
	1.2 kW	GAM2AB120B0XRK□*	GAM2AB120B0CRK□*	GAM2AB120B0XNK□*	GAM2AB120B0CNK□*	p. 38	30 A
		GAM2AB120H0XRK□	GAM2AB120H0CRK□	GAM2AB120H0XNK□	GAM2AB120H0CNK□	p. 38	50 A
		GAM2AB120D0XRK□	GAM2AB120D0CRK□	GAM2AB120D0XNK□	GAM2AB120D0CNK□	p. 38	50 A

Note: The □ symbol in the model number denotes the following:

0: Circular shaft (without key) without oil seal

1: Circular shaft (without key) with oil seal

2: Keyway shaft without oil seal

3: Keyway shaft with oil seal

The motor outputs may be derated to 80 to 95% of the rated values due to the combined brake and oil seal.

* GAM2A9100H0, GAM2AB120B0...When using a single-phase input power supply for the servo amplifier, make sure that the servo motor output is 750 W or less by adjusting the torque and speed.

Standard Model Number List

200 V Linear Servo Motor

Type	Model no.				Page	Compatible servo amplifier capacity
	Coil		Magnet rail			
	Without hall sensor	With hall sensor	Without magnet cover	With magnet cover		
Flat type with core	DS025CC1ANAA△00	DS025CC1ANEA△00	DS025MC□□□A00	DS025MC□□□B00	p. 44	20 A
	DS035CC1ANAA△00	DS035CC1ANEA△00	DS035MC□□□A00	DS035MC□□□B00	p. 45	30 A
	DS045CC1ANAA△00	DS045CC1ANEA△00	DS045MC□□□A00	DS045MC□□□B00	p. 45	30 A
	DS055CC1ANAA△00	DS055CC1ANEA△00	DS055MC□□□A00	DS055MC□□□B00	p. 45	30 A
	DS065CC1ANAA△00	DS065CC1ANEA△00	DS065MC□□□A00	DS065MC□□□B00	p. 45	50 A
	DS050CD1ANAA△00	DS050CD1ANEA△00	DS050MD□□□A00	DS050MD□□□B00	p. 46	30 A
Center magnet type with core	DT030CD1ANAA△00	DT030CD1ANEA△00	DT030M□□□A00	DT030M□□□B00	p. 47	30 A

Note 1: The △ symbol in the model number denotes the following:

1: Cable length 300 mm 2: Cable length 600 mm

Note 2: The □ symbols in the model number denote the following:

064: Magnet rail length 64 mm 128: Magnet rail length 128 mm 256: Magnet rail length 256 mm 512: Magnet rail length 512 mm

A model with a 64 mm magnet rail length is not available for the center magnet type.

200 V Servo Amplifier

Analog/Pulse Input Type Standard specifications... Standards conformity: UL, cUL, CE, UKCA, KC mark (KC mark applies to servo amplifiers only)

Input voltage	GPO	Regenerative resistor	STO function	Amplifier capacity	Model no.	Page	
						Specifications	Dimensions
200 VAC class 200 to 240 VAC 3-/single-phase	Sinking type	Built-in	✓ (Without delay circuit)	10 A	GADSA01AA22	p. 52	p. 54
				20 A	GADSA02AA22	p. 52	p. 54
				30 A	GADSA03AA22	p. 52	p. 54
				50 A	GADSA05AA22	p. 52	p. 54
		External	✓ (Without delay circuit)	10 A	GADSA01LA22	p. 52	p. 54
				20 A	GADSA02LA22	p. 52	p. 54
				30 A	GADSA03LA22	p. 52	p. 54
				50 A	GADSA05LA22	p. 52	p. 54
	Sourcing type	Built-in	✓ (Without delay circuit)	10 A	GADSA01AB22	p. 52	p. 54
				20 A	GADSA02AB22	p. 52	p. 54
				30 A	GADSA03AB22	p. 52	p. 54
				50 A	GADSA05AB22	p. 52	p. 54
		External	✓ (Without delay circuit)	10 A	GADSA01LB22	p. 52	p. 54
				20 A	GADSA02LB22	p. 52	p. 54
				30 A	GADSA03LB22	p. 52	p. 54
				50 A	GADSA05LB22	p. 52	p. 54

EtherCAT Interface Type Standard specifications... Standards conformity: UL, cUL, CE, UKCA, KC mark (KC mark applies to servo amplifiers only)

Input voltage	GPO	Regenerative resistor	STO function	Amplifier capacity	Model no.	Page	
						Specifications	Dimensions
200 VAC class 200 to 240 VAC 3-/single-phase	Sinking/ Sourcing type	Built-in	✓ (with delay circuit)	10 A	GADSA01AH24	p. 60	p. 61
				20 A	GADSA02AH24	p. 60	p. 61
				30 A	GADSA03AH24	p. 60	p. 61
				50 A	GADSA05AH24	p. 60	p. 61
		External	✓ (with delay circuit)	10 A	GADSA01LH24	p. 60	p. 61
				20 A	GADSA02LH24	p. 60	p. 61
				30 A	GADSA03LH24	p. 60	p. 61
				50 A	GADSA05LH24	p. 60	p. 61

100 V

Low-inertia Servo Motor

Standard specifications... Ingress protection: IP67, standards conformity: UL, cUL, CE, UKCA

Motor flange size	Rated output	Model no.				Page	Compatible servo amplifier capacity
		Battery-less absolute encoder		Single-turn absolute encoder			
		Without holding brake	With holding brake	Without holding brake	With holding brake		
40 mm sq.	50 W	GAM1E4005F0XRK□	GAM1E4005F0CRK□	GAM1E4005F0XNK□	GAM1E4005F0CNK□	p. 26	20 A
	100 W	GAM1E4010F0XRK□	GAM1E4010F0CRK□	GAM1E4010F0XNK□	GAM1E4010F0CNK□	p. 26	20 A
60 mm sq.	200 W	GAM1E6020F0XRK□	GAM1E6020F0CRK□	GAM1E6020F0XNK□	GAM1E6020F0CNK□	p. 27	30 A

100 V

Medium-inertia Servo Motor

Standard specifications... Ingress protection: IP67, standards conformity: UL, cUL, CE, UKCA

Motor flange size	Rated output	Model no.				Page	Compatible servo amplifier capacity
		Battery-less absolute encoder		Single-turn absolute encoder			
		Without holding brake	With holding brake	Without holding brake	With holding brake		
40 mm sq.	30 W	GAM2E4003F0XRK□	GAM2E4003F0CRK□	GAM2E4003F0XNK□	GAM2E4003F0CNK□	p. 40	10 A
	50 W	GAM2E4005F0XRK□	GAM2E4005F0CRK□	GAM2E4005F0XNK□	GAM2E4005F0CNK□	p. 40	20 A
	100 W	GAM2E4010F0XRK□	GAM2E4010F0CRK□	GAM2E4010F0XNK□	GAM2E4010F0CNK□	p. 40	20 A
60 mm sq.	100 W	GAM2E6010F0XRK□	GAM2E6010F0CRK□	GAM2E6010F0XNK□	GAM2E6010F0CNK□	p. 41	20 A
	200 W	GAM2E6020F0XRK□	GAM2E6020F0CRK□	GAM2E6020F0XNK□	GAM2E6020F0CNK□	p. 41	30 A

Note: The □ symbol in the model number denotes the following:

0: Circular shaft (without key) without oil seal

1: Circular shaft (without key) with oil seal

2: Keyway shaft without oil seal

3: Keyway shaft with oil seal

Standard Model Number List

100 V

Servo Amplifier

Analog/Pulse Input Type Standard specifications... Standards conformity: UL, cUL, CE, UKCA, KC mark (KC mark applies to servo amplifiers only)

Input voltage	GPO	Regenerative resistor	STO function	Amplifier capacity	Model no.	Page	
						Specifications	Dimensions
100 VAC class 100 to 120 VAC Single-phase	Sinking type	Built-in	✓ (Without delay circuit)	10 A	GADSE01AA22	p. 52	p. 54
				20 A	GADSE02AA22	p. 52	p. 54
				30 A	GADSE03AA22	p. 52	p. 54
		External	✓ (Without delay circuit)	10 A	GADSE01LA22	p. 52	p. 54
				20 A	GADSE02LA22	p. 52	p. 54
				30 A	GADSE03LA22	p. 52	p. 54
	Sourcing type	Built-in	✓ (Without delay circuit)	10 A	GADSE01AB22	p. 52	p. 54
				20 A	GADSE02AB22	p. 52	p. 54
				30 A	GADSE03AB22	p. 52	p. 54
		External	✓ (Without delay circuit)	10 A	GADSE01LB22	p. 52	p. 54
				20 A	GADSE02LB22	p. 52	p. 54
				30 A	GADSE03LB22	p. 52	p. 54

EtherCAT Interface Type Standard specifications... Standards conformity: UL, cUL, CE, UKCA, KC mark (KC mark applies to servo amplifiers only)

Input voltage	GPO	Regenerative resistor	STO function	Amplifier capacity	Model no.	Page	
						Specifications	Dimensions
100 VAC class 100 to 120 VAC Single-phase	Sinking/ Sourcing type	Built-in	✓ (with delay circuit)	10 A	GADSE01AH24	p. 60	p. 61
				20 A	GADSE02AH24	p. 60	p. 61
				30 A	GADSE03AH24	p. 60	p. 61
		External	✓ (with delay circuit)	10 A	GADSE01LH24	p. 60	p. 61
				20 A	GADSE02LH24	p. 60	p. 61
				30 A	GADSE03LH24	p. 60	p. 61

STO delay circuit of servo amplifiers

Two types are available: "without delay circuit" and "with delay circuit" between the input circuits of safety input 1 (HWGOFF1)/ safety input 2 (HWGOFF2) and the control signal blocking circuit.

For vertical axis applications, models with a delay circuit can prevent the motor shaft from falling due to a delay in the holding brake when the STO function is activated.

Servo amplifier model no.	Delay circuit (Delay time)
GADS□□□□□□2	Without delay circuit (0 to 20 ms)
GADS□□□□□□4	With delay circuit (200 to 700 ms)

Note 1: Even models without delay circuit have delay of up to 20 ms before the STO function is activated due to a delay in the input circuit.

Note 2: Holding brake excitation signal and servo motor holding brake are not safety-related parts.

Servo Motors

Rotary motors

Output capacity: 30 W to 1.5 kW



How to read model numbers

Note that not all possible combinations of field values may yield valid products. Also, some of the values listed below are for options. Refer to the Standard Model Number List section for standard models with valid model numbers.

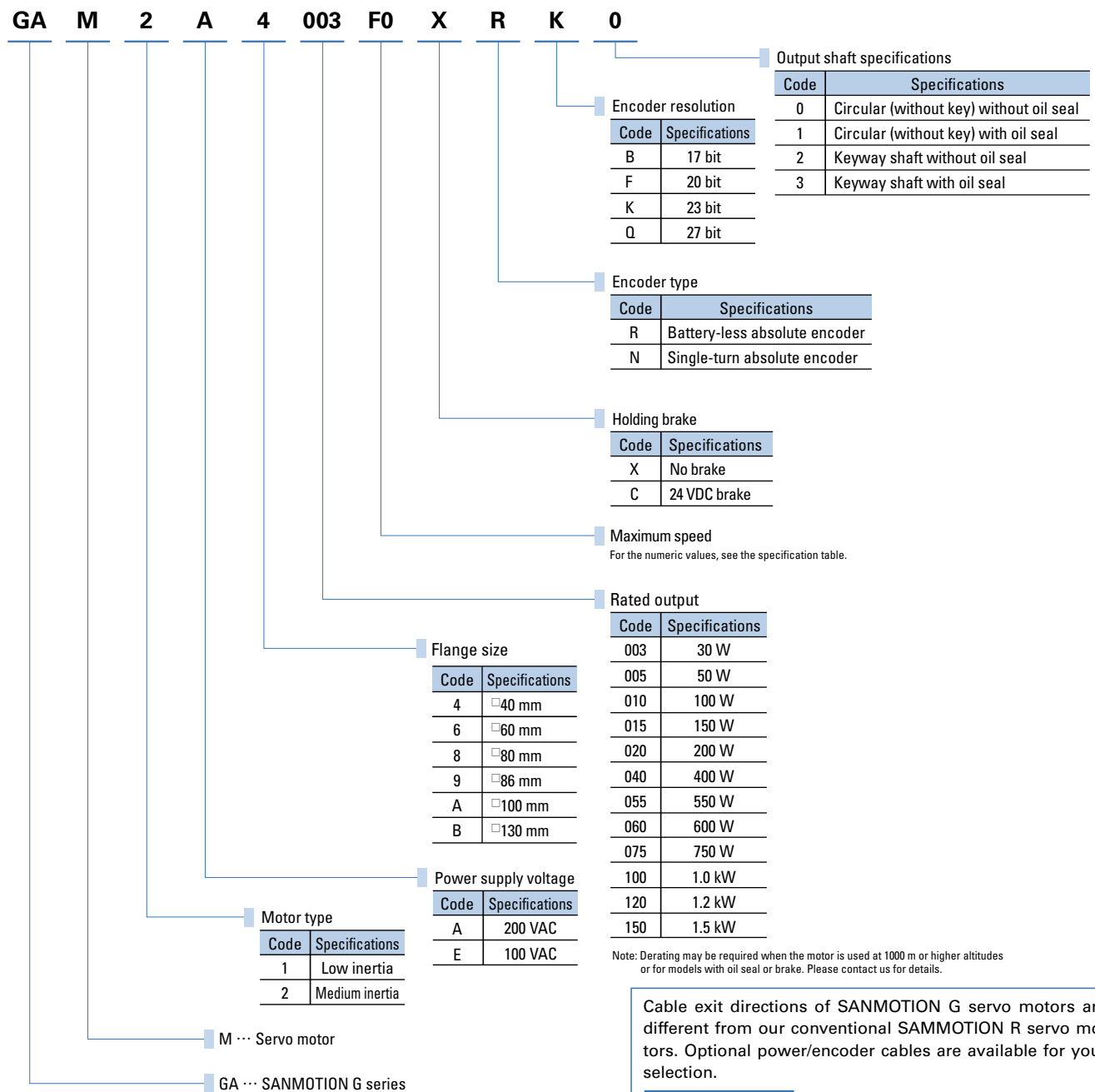

Cable exit directions of SANMOTION G servo motors are different from our conventional SAMMOTION R servo motors. Optional power/encoder cables are available for your selection.

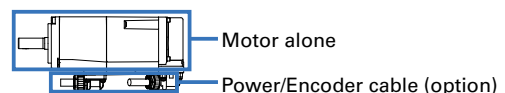

40 mm sq.

Servo motor model no.			GAM1A4005F0	GAM1A4010F0	GAM1A4015F0	
	Symbol	Unit				
★ Rated output	P _R	kW	0.05	0.10	0.15	
★ Rated torque	T _R	N · m	0.159	0.318	0.48	
★ Continuous torque at stall	T _S	N · m	0.167	0.353	0.525	
★ Peak torque at stall	T _P	N · m	0.56	1.18	1.67	
★ Rated speed	N _R	min ⁻¹	3000	3000	3000	
★ Maximum speed	N _{max}	min ⁻¹	6500	6500	6500	
★ Rated armature current	I _R	Arms	0.81	1.0	1.7	
★ Continuous armature current at stall	I _S	Arms	0.81	1.05	1.8	
★ Peak armature current at stall	I _P	Arms	2.9	4.1	6.4	
Torque constant	K _T	N · m/Arms	0.244	0.372	0.327	
Phase resistance	R _ø	Ω	7.0	6.9	3.9	
Rotor inertia	Without brake	J _M	×10 ⁻⁴ kg·m ² (GD ² /4)	0.0153	0.0259	0.0354
	With brake			0.0218	0.0324	0.0419
Encoder inertia*	J _S		0.0025	0.0025	0.0025	
★ Rated power rate	Without brake	Q _R	kW/s	17	39	65
	With brake			12	31	55
Servo motor mass*	Without brake	W _E	kg	0.38	0.52	0.66
	With brake			0.57	0.71	0.85
Size of heat dissipation aluminum plate	—	mm	250 × 250 × 6	250 × 250 × 6	305 × 305 × 12	
Holding brake static friction torque	T _b	N·m	0.48 or greater	0.48 or greater	0.48 or greater	
Holding brake rated voltage	V _b	V	24 DC ±10%	24 DC ±10%	24 DC ±10%	
Holding brake current consumption	I _b	A	0.26	0.26	0.26	
Holding brake engage time		ms	30 or less	30 or less	30 or less	
Holding brake release time (varistor)		ms	20 or less	20 or less	20 or less	
Holding brake release time (diode)		ms	100 or less	100 or less	100 or less	
Compatible servo amplifier model no.	—		GADSA01 (10 A)	GADSA01 (10 A)	GADSA02 (20 A)	

Speed-Torque Characteristics 3ø: When the power supply voltage is 3-phase, 1ø: When the power supply voltage is single-phase

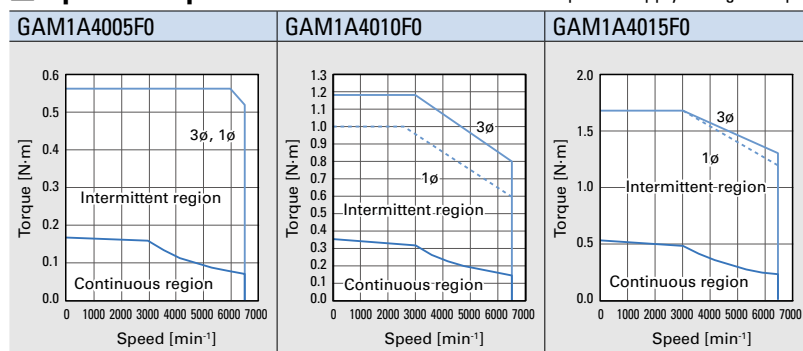

Note 1: Speed-torque characteristics curves and values in the row with a black star symbol (★) are the values after thermal equilibrium is established. All other values are at a temperature of 20°C.

Note 2: All values are typical values. Torque constant is the value when mounted on the heat dissipation aluminum plate in the table.

Note 3: The holding brake cannot be used for dynamic braking. Holding brake engage/release time denotes the delay time of holding brake activation.

Values of holding brake engage/release time vary depending on the circuit used. Please check the delay time on the actual equipment before use.

* The encoder inertia and servo motor mass values are when equipped with a battery-less absolute encoder. Contact us for more information on other encoders.

■ Dimensions [Unit: mm]

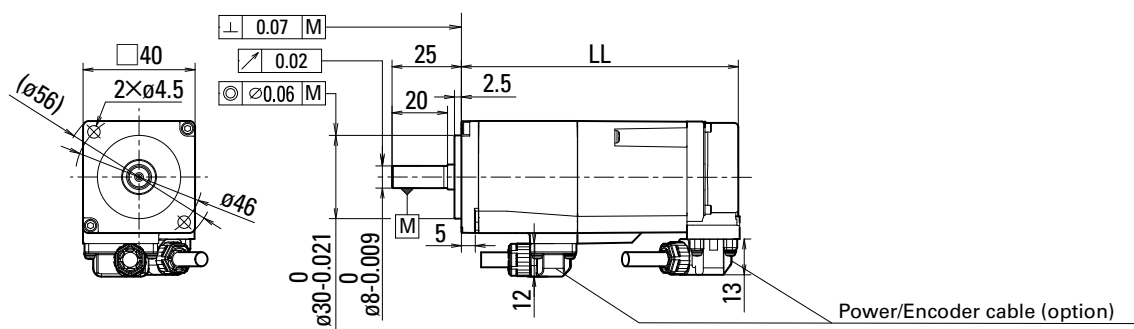

Servo motor model no.	Without oil seal		With oil seal	
	Without brake	With brake	Without brake	With brake
GAM1□4005	LL	LL	LL	LL
GAM1□4010	74.5	103	79.5	108
GAM1□4015	93.5	122	98.5	127
GAM1□4015	112.5	141	117.5	146

Options

■ **Power/Encoder cable** Front and rear cable exits are directed to the output shaft direction and the opposite direction, respectively.

Cable model no.		Cable exit direction	Cable length [m]
Power	Encoder		
GSSF0100S	GESF0100S	Front	1
GSSR0100S	GESR0100S	Rear	1
GSSF0300S	GESF0300S	Front	3
GSSR0300S	GESR0300S	Rear	3
GSSF0500S	GESF0500S	Front	5
GSSR0500S	GESR0500S	Rear	5

Plug specifications

■ **Motor power / holding brake plug (motor side)** Manufacturer: Japan Aviation Electronics Industry, Ltd.

Cable exit direction	Plug mfr. part no.	Compatible cable diameter	Contact mfr. part no.		Compatible wire diameter (including insulation)		Compatible wire size (AWG)	
			Power	Brake	Power	Brake	Power	Brake
Front	JN16FE06SS1	ø5.2 to 5.6 mm	JN16S10K4A1		ø1.1 to 1.55 mm		22	24
Rear	JN16FE06SS2							

■ **Encoder plug (motor side)** Manufacturer: Japan Aviation Electronics Industry, Ltd.

Cable exit direction	Plug mfr. part no.	Compatible cable diameter	Contact mfr. part no.	Compatible wire diameter (including insulation)	Compatible wire size (AWG)
Front	JN16FS09SS1	ø4.9 to 5.6 mm	JN-24S-C2B-B1-10000	ø0.7 to 0.9 mm	26
Rear	JN16FS09SS2				

Note 1: Plugs and contacts are not provided. Please contact the connector manufacturer.

Note 2: See the catalogs and instruction manuals issued by the connector manufacturer (Japan Aviation Electronics Industry, Ltd.) for handling and safety precautions.

60 mm sq.

Servo motor model no.			GAM1A6020F0	GAM1A6040F0	GAM1A6060F0	
	Symbol	Unit				
★ Rated output	P _R	kW	0.2	0.4	0.6	
★ Rated torque	T _R	N · m	0.637	1.27	1.91	
★ Continuous torque at stall	T _S	N · m	0.686	1.37	1.91	
★ Peak torque at stall	T _P	N · m	2.2	4.8	6.7	
★ Rated speed	N _R	min ⁻¹	3000	3000	3000	
★ Maximum speed	N _{max}	min ⁻¹	6500	6500	6500	
★ Rated armature current	I _R	Arms	1.51	2.8	5.1	
★ Continuous armature current at stall	I _S	Arms	1.52	2.8	4.7	
★ Peak armature current at stall	I _P	Arms	5.8	12.0	20.5	
Torque constant	K _T	N · m/Arms	0.519	0.544	0.456	
Phase resistance	R _ø	Ω	3.8	1.5	0.71	
Rotor inertia	Without brake	J _M	×10 ⁻⁴ kg·m ² (GD ² /4)	0.121	0.213	0.287
	With brake			0.182	0.272	0.348
Encoder inertia*	J _S		0.0025	0.0025	0.0025	
★ Rated power rate	Without brake	Q _R	kW/s	34	76	127
	With brake			22	59	105
Servo motor mass*	Without brake	W _E	kg	0.94	1.4	1.9
	With brake			1.4	1.8	2.3
Size of heat dissipation aluminum plate	—	mm	250 × 250 × 6	250 × 250 × 6	305 × 305 × 12	
Holding brake static friction torque	T _b	N·m	1.37 or greater	1.37 or greater	1.91 or greater	
Holding brake rated voltage	V _b	V	24 DC ±10%	24 DC ±10%	24 DC ±10%	
Holding brake current consumption	I _b	A	0.29	0.29	0.32	
Holding brake engage time		ms	30 or less	30 or less	40 or less	
Holding brake release time (varistor)		ms	20 or less	20 or less	20 or less	
Holding brake release time (diode)		ms	120 or less	120 or less	120 or less	
Compatible servo amplifier model no.	—		GADSA02 (20 A)	GADSA02 (20 A)	GADSA05 (50 A)	

Speed-Torque Characteristics 3ø: When the power supply voltage is 3-phase, 1ø: When the power supply voltage is single-phase

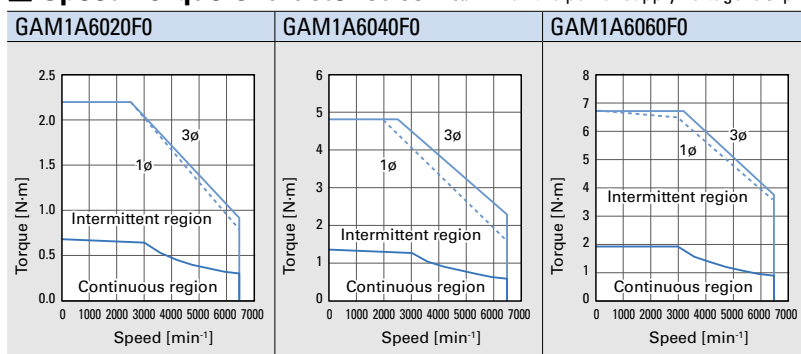

Note: GAM1A6040* and GAM1A6060* models may be derated with brake or oil seal.

Note 1: Speed-torque characteristics curves and values in the row with a black star symbol (★) are the values after thermal equilibrium is established. All other values are at a temperature of 20°C.

Note 2: All values are typical values. Torque constant is the value when mounted on the heat dissipation aluminum plate in the table.

Note 3: The holding brake cannot be used for dynamic braking. Holding brake engage/release time denotes the delay time of holding brake activation.

Values of holding brake engage/release time vary depending on the circuit used. Please check the delay time on the actual equipment before use.

* The encoder inertia and servo motor mass values are when equipped with a battery-less absolute encoder. Contact us for more information on other encoders.

■ Dimensions [Unit: mm]

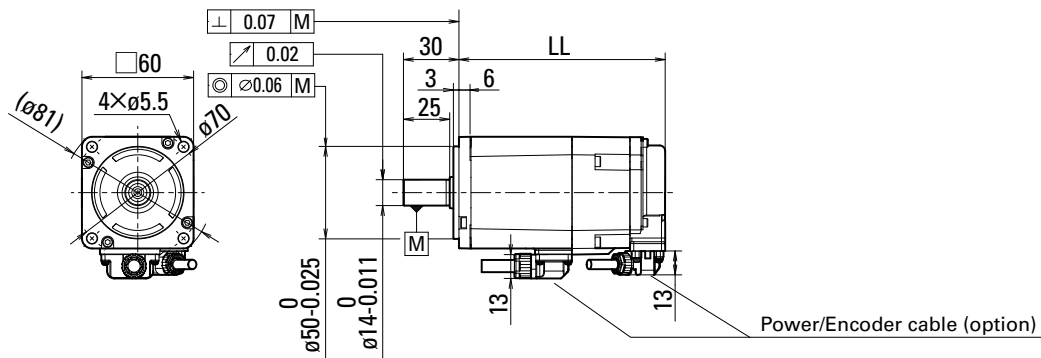

Servo motor model no.	Without oil seal		With oil seal	
	Without brake	With brake	Without brake	With brake
GAM1□6020	85.5	108.5	92.5	115.5
GAM1□6040	110	132.5	117	139.5
GAM1□6060	144	169	151	176

Options

■ **Power/Encoder cable** Front and rear cable exits are directed to the output shaft direction and the opposite direction, respectively.

Cable model no.		Cable exit direction	Cable length [m]
Power	Encoder		
GMSF0100S	GESF0100S	Front	1
GMSR0100S	GESR0100S	Rear	1
GMSF0300S	GESF0300S	Front	3
GMSR0300S	GESR0300S	Rear	3
GMSF0500S	GESF0500S	Front	5
GMSR0500S	GESR0500S	Rear	5

Plug specifications

■ **Motor power / holding brake plug (motor side)** Manufacturer: Japan Aviation Electronics Industry, Ltd.

Cable exit direction	Plug mfr. part no.	Compatible cable diameter	Contact mfr. part no.		Compatible wire diameter (including insulation)		Compatible wire size (AWG)	
			Power	Brake	Power	Brake	Power	Brake
Front	JN16FG06SS1	ø6.3 to 6.9 mm	JN16S25H3A1	JN16S10K4A1	ø1.2 to 1.85 mm	ø1.1 to 1.55 mm	19	23
Rear	JN16FG06SS2							

■ **Encoder plug (motor side)** Manufacturer: Japan Aviation Electronics Industry, Ltd.

Cable exit direction	Plug mfr. part no.	Compatible cable diameter	Contact mfr. part no.	Compatible wire diameter (including insulation)	Compatible wire size (AWG)
Front	JN16FS09SS1	ø4.9 to 5.6 mm	JN-24S-C2B-B1-10000	ø0.7 to 0.9 mm	26
Rear	JN16FS09SS2				

Note 1: Plugs and contacts are not provided. Please contact the connector manufacturer.

Note 2: See the catalogs and instruction manuals issued by the connector manufacturer (Japan Aviation Electronics Industry, Ltd.) for handling and safety precautions.

80 mm sq.

Servo motor model no.			GAM1A8075V0	GAM1A8075F0	GAM1A8100F0
	Symbol	Unit			
★ Rated output	P _R	kW	0.75	0.75	1.0
★ Rated torque	T _R	N · m	2.39	2.39	3.18
★ Continuous torque at stall	T _S	N · m	2.55	2.55	3.50
★ Peak torque at stall	T _P	N · m	8.5	8.5	11.1
★ Rated speed	N _R	min ⁻¹	3000	3000	3000
★ Maximum speed	N _{max}	min ⁻¹	6500	6500	6500
★ Rated armature current	I _R	Arms	4.2	5.9	6.8
★ Continuous armature current at stall	I _S	Arms	4.1	5.7	6.8
★ Peak armature current at stall	I _P	Arms	15.5	22.0	26.5
Torque constant	K _T	N · m/Arms	0.670	0.501	0.561
Phase resistance	R _ϕ	Ω	0.61	0.32	0.31
Rotor inertia	Without brake	J _M ×10 ⁻⁴ kg·m ² (GD ² /4)	0.739	0.739	0.959
	With brake		0.936	0.936	1.16
Encoder inertia*	J _S		0.0025	0.0025	0.0025
★ Rated power rate	Without brake	Q _R	77	77	105
	With brake		61	61	88
Servo motor mass*	Without brake	W _E	2.9	2.9	3.5
	With brake		3.7	3.7	4.3
Size of heat dissipation aluminum plate	—	mm	250 × 250 × 6	250 × 250 × 6	305 × 305 × 12
Holding brake static friction torque	T _b	N·m	3.18 or greater	3.18 or greater	3.18 or greater
Holding brake rated voltage	V _b	V	24 DC ±10%	24 DC ±10%	24 DC ±10%
Holding brake current consumption	I _b	A	0.33	0.33	0.33
Holding brake engage time		ms	50 or less	50 or less	50 or less
Holding brake release time (varistor)		ms	30 or less	30 or less	30 or less
Holding brake release time (diode)		ms	200 or less	200 or less	200 or less
Compatible servo amplifier model no.	—		GADSA03 (30 A)	GADSA05 (50 A)	GADSA05 (50 A)

Speed-Torque Characteristics 3ϕ: When the power supply voltage is 3-phase, 1ϕ: When the power supply voltage is single-phase

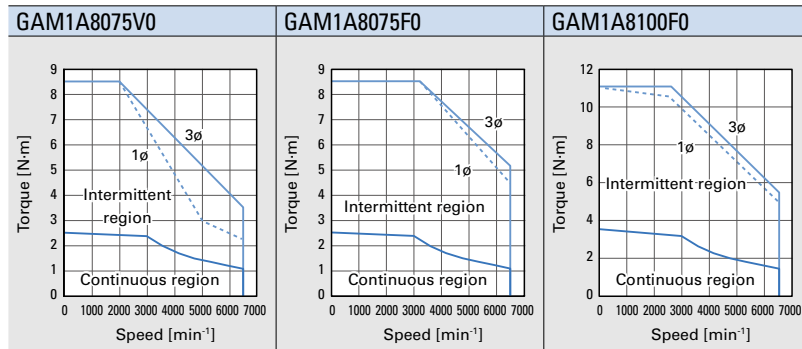

Note: GAM1A8075* models may be derated with brake or oil seal.

Note 1: Speed-torque characteristics curves and values in the row with a black star symbol (★) are the values after thermal equilibrium is established. All other values are at a temperature of 20°C.

Note 2: All values are typical values. Torque constant is the value when mounted on the heat dissipation aluminum plate in the table.

Note 3: The holding brake cannot be used for dynamic braking. Holding brake engage/release time denotes the delay time of holding brake activation.

Values of holding brake engage/release time vary depending on the circuit used. Please check the delay time on the actual equipment before use.

* The encoder inertia and servo motor mass values are when equipped with a battery-less absolute encoder. Contact us for more information on other encoders.

■ Dimensions [Unit: mm]

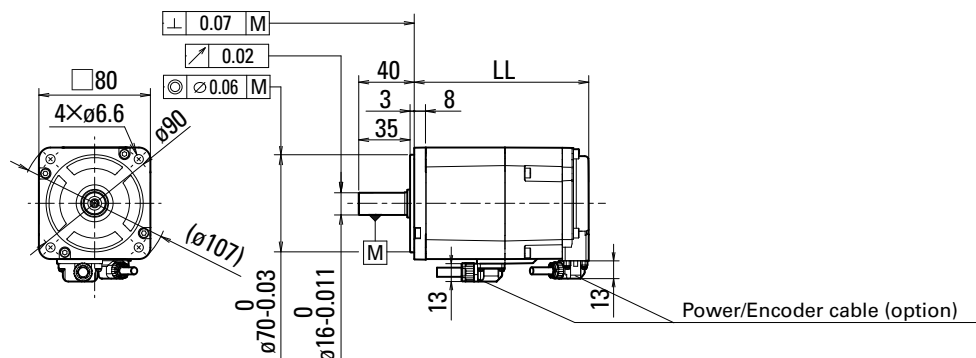

Servo motor model no.	Without oil seal		With oil seal	
	Without brake	With brake	Without brake	With brake
GAM1□8075	125	155.5	132	162.5
GAM1□8100	153	183.5	160	190.5

Options

■ **Power/Encoder cable** Front and rear cable exits are directed to the output shaft direction and the opposite direction, respectively.

Cable model no.		Cable exit direction	Cable length [m]
Power	Encoder		
GMSF0100S	GESF0100S	Front	1
GMSR0100S	GESR0100S	Rear	1
GMSF0300S	GESF0300S	Front	3
GMSR0300S	GESR0300S	Rear	3
GMSF0500S	GESF0500S	Front	5
GMSR0500S	GESR0500S	Rear	5

Plug specifications

■ **Motor power / holding brake plug (motor side)** Manufacturer: Japan Aviation Electronics Industry, Ltd.

Cable exit direction	Plug mfr. part no.	Compatible cable diameter	Contact mfr. part no.		Compatible wire diameter (including insulation)		Compatible wire size (AWG)	
			Power	Brake	Power	Brake	Power	Brake
Front	JN16FG06SS1	ø6.3 to 6.9 mm	JN16S25H3A1	JN16S10K4A1	ø1.2 to 1.85 mm	ø1.1 to 1.55 mm	19	23
Rear	JN16FG06SS2							

■ **Encoder plug (motor side)** Manufacturer: Japan Aviation Electronics Industry, Ltd.

Cable exit direction	Plug mfr. part no.	Compatible cable diameter	Contact mfr. part no.	Compatible wire diameter (including insulation)	Compatible wire size (AWG)
Front	JN16FS09SS1	ø4.9 to 5.6 mm	JN-24S-C2B-B1-10000	ø0.7 to 0.9 mm	26
Rear	JN16FS09SS2				

Note 1: Plugs and contacts are not provided. Please contact the connector manufacturer.

Note 2: See the catalogs and instruction manuals issued by the connector manufacturer (Japan Aviation Electronics Industry, Ltd.) for handling and safety precautions.



100 mm sq.

Servo motor model no.			GAM1AA100H0	GAM1AA100F0	GAM1AA150H0	GAM1AA150F0	
	Symbol	Unit					
★ Rated output	P _R	kW	1.0	1.0	1.5	1.5	
★ Rated torque	T _R	N · m	3.2	3.2	4.8	4.8	
★ Continuous torque at stall	T _S	N · m	3.2	3.2	4.9	4.9	
★ Peak torque at stall	T _P	N · m	12.6	10.5	18.0	15.0	
★ Rated speed	N _R	min ⁻¹	3000	3000	3000	3000	
★ Maximum speed	N _{max}	min ⁻¹	3000	6000	3000	6000	
★ Rated armature current	I _R	Arms	4.5	7.7	5.2	8.7	
★ Continuous armature current at stall	I _S	Arms	3.8	7.4	3.8	8.2	
★ Peak armature current at stall	I _P	Arms	16.3	26.5	15.5	26.5	
Torque constant	K _T	N · m/Arms	0.971	0.456	1.35	0.642	
Phase resistance	R _φ	Ω	1.40	0.27	1.26	0.26	
Rotor inertia	Without brake	J _M	×10 ⁻⁴ kg·m ² (GD ² /4)	1.33	1.33	1.98	1.98
	With brake			1.66	1.66	2.31	2.31
Encoder inertia*	J _S		0.0025	0.0025	0.0025	0.0025	
★ Rated power rate	Without brake	Q _R	kW/s	77	77	116	116
	With brake			62	62	100	100
Servo motor mass*	Without brake	W _E	kg	3.8	3.8	5.0	5.0
	With brake			5.3	5.3	6.6	6.6
Size of heat dissipation aluminum plate	—	mm	400 × 400 × 20	400 × 400 × 20	400 × 400 × 20	400 × 400 × 20	
Holding brake static friction torque	T _b	N·m	8 or greater	8 or greater	8 or greater	8 or greater	
Holding brake rated voltage	V _b	V	24 DC ±10%	24 DC ±10%	24 DC ±10%	24 DC ±10%	
Holding brake current consumption	I _b	A	0.67	0.67	0.67	0.67	
Holding brake engage time		ms	100 or less	100 or less	100 or less	100 or less	
Holding brake release time (varistor)		ms	30 or less	30 or less	30 or less	30 or less	
Holding brake release time (diode)		ms	200 or less	200 or less	200 or less	200 or less	
Compatible servo amplifier model no.	—		GADSA03 (30 A)	GADSA05 (50 A)	GADSA03 (30 A)	GADSA05 (50 A)	

Speed-Torque Characteristics

3φ: When the power supply voltage is 3-phase, 1φ: When the power supply voltage is single-phase (the rated output of GAM1AA100H and GAM1AA150H0 are 750 W)

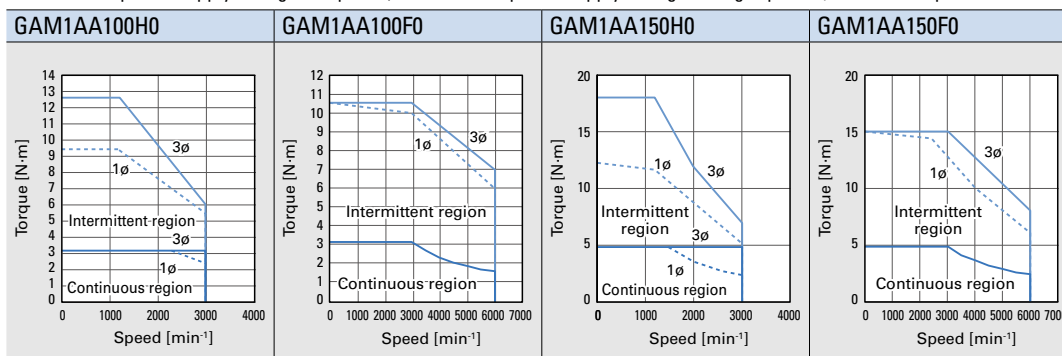

Note 1: Speed-torque characteristics curves and values in the row with a black star symbol (★) are the values after thermal equilibrium is established. All other values are at a temperature of 20°C.

Note 2: All values are typical values. Torque constant is the value when mounted on the heat dissipation aluminum plate in the table.

Note 3: The holding brake cannot be used for dynamic braking. Holding brake engage/release time denotes the delay time of holding brake activation.

Values of holding brake engage/release time vary depending on the circuit used. Please check the delay time on the actual equipment before use.

* The encoder inertia and servo motor mass values are when equipped with a battery-less absolute encoder. Contact us for more information on other encoders.

■ Dimensions [Unit: mm] The LL value does not change with or without oil seal.

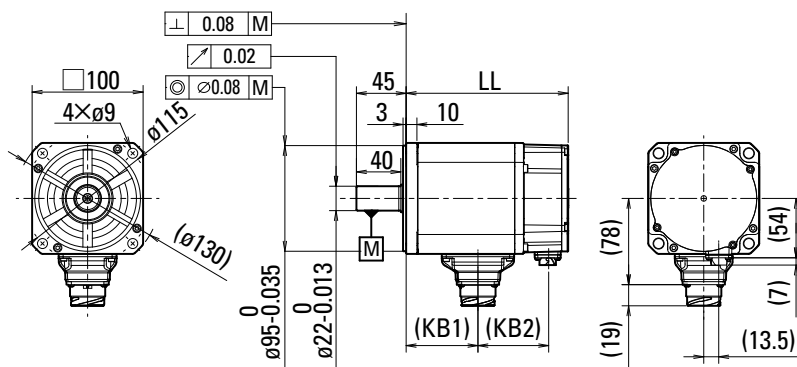

Servo motor model no.	Without brake		With brake		Without brake		With brake	
	LL	LL	KB1	KB2	KB1	KB2	KB1	KB2
GAM1□A100	132.5	169	61	53	61	90	61	90
GAM1□A150	156.5	193	85	53	85	90	85	90

Options

■ Power/Encoder cable

Cable model no.			Cable length [m]
Power (without brake)	Power (with brake)	Encoder	
GPPB0100S	GQP B0100SB	RS-CA9-01-R	1
GPPB0300S	GQP B0300SB	RS-CA9-03-R	3
GPPB0500S	GQP B0500SB	RS-CA9-05-R	5

Plug specifications

■ Motor power / holding brake plug (motor side) Manufacturer: Japan Aviation Electronics Industry, Ltd.

Holding brake	Receptacle mfr. part no.	Pin assignment					Recommended motor power cable size (U, V, W, and ground)	
		U phase	V phase	W phase	Ground	Brake	mm ²	AWG No.
None	JL10-2E20-4PE-B	A	B	C	D	—	2.0	14
Yes	JL10-2E20-18PE-B	F	I	B	E, D	G, H	2.0	14

Holding brake	Plug mfr. part no.		Cable clamp	
	Straight	Angled	Mfr. part no.	Compatible cable outer diameter
None	JL10-6A20-4SE-EB	JL10-8A20-4SE-EB	JL04V-2022CK(14)-R	ø12.9 to 16 mm
Yes	JL10-6A20-18SE-EB	JL10-8A20-18SE-EB	JL04V-2022CK(14)-R	ø12.9 to 16 mm

■ Encoder plug (motor side) Manufacturer: Japan Aviation Electronics Industry, Ltd.

Receptacle mfr. part no.	Plug mfr. part no.		Compatible cable diameter	Contact Size	Classification	Applicable socket contact	
	Straight	Angled				Mfr. part no.	Compatible wire size
JN2AS10ML2-R	JN2DS10SL1-R	JN2FS10SL1-R	ø5.7 to 7.3 mm	#22	Manual crimping tool Type	JN1-22-20S-R-PKG100	AWG 20
	JN2DS10SL2-R	JN2FS10SL2-R	ø6.5 to 8.0 mm			JN1-22-22S-PKG100	AWG 25 to 21
	JN2DS10SL3-R	JN2FS10SL3-R	ø3.5 to 5.0 mm			JN1-22-26S-PKG100	AWG 28 to 26
			Soldering type			JN1-22-22F-PKG100	AWG 20 or smaller

Note: See the catalogs and instruction manuals issued by the connector manufacturer (Japan Aviation Electronics Industry, Ltd.) for handling and safety precautions.

40 mm sq.

Servo motor model no.			GAM1E4005F0	GAM1E4010F0
	Symbol	Unit		
★ Rated output	P _R	kW	0.05	0.1
★ Rated torque	T _R	N · m	0.159	0.318
★ Continuous torque at stall	T _S	N · m	0.167	0.318
★ Peak torque at stall	T _P	N · m	0.56	1.11
★ Rated speed	N _R	min ⁻¹	3000	3000
★ Maximum speed	N _{max}	min ⁻¹	6500	6500
★ Rated armature current	I _R	Arms	1.35	1.75
★ Continuous armature current at stall	I _S	Arms	1.35	1.70
★ Peak armature current at stall	I _P	Arms	5.5	6.8
Torque constant	K _T	N · m/Arms	0.140	0.209
Phase resistance	R _θ	Ω	2.30	2.30
Rotor inertia	Without brake	J _M	×10 ⁻⁴ kg·m ² (GD ² /4)	0.0153
	With brake			0.0218
Encoder inertia*	J _S			0.0025
★ Rated power rate	Without brake	Q _R	kW/s	17
	With brake			12
Servo motor mass*	Without brake	W _E	kg	0.38
	With brake			0.57
Size of heat dissipation aluminum plate	—	mm	250 × 250 × 6	250 × 250 × 6
Holding brake static friction torque	T _b	N·m	0.48 or greater	0.48 or greater
Holding brake rated voltage	V _b	V	24 DC ±10%	24 DC ±10%
Holding brake current consumption	I _b	A	0.26	0.26
Holding brake engage time		ms	30 or less	30 or less
Holding brake release time (varistor)		ms	20 or less	20 or less
Holding brake release time (diode)		ms	100 or less	100 or less
Compatible servo amplifier model no.	—		GADSE02 (20 A)	GADSE02 (20 A)

Speed-Torque Characteristics

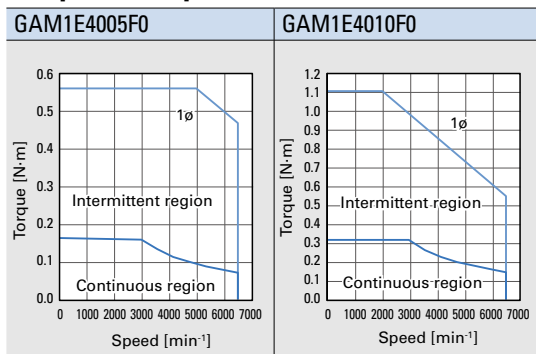

Note 1: Speed-torque characteristics curves and values in the row with a black star symbol (★) are the values after thermal equilibrium is established. All other values are at a temperature of 20°C.

Note 2: All values are typical values. Torque constant is the value when mounted on the heat dissipation aluminum plate in the table.

Note 3: The holding brake cannot be used for dynamic braking. Holding brake engage/release time denotes the delay time of holding brake activation.

Values of holding brake engage/release time vary depending on the circuit used. Please check the delay time on the actual equipment before use.

* The encoder inertia and servo motor mass values are when equipped with a battery-less absolute encoder. Contact us for more information on other encoders.

Dimensions/Options/Plug specifications Common to 40 mm sq. 200 V servo motors on p. 19

60 mm sq.

Servo motor model no.			GAM1E6020F0
	Symbol	Unit	
★ Rated output	P _R	kW	0.2
★ Rated torque	T _R	N · m	0.637
★ Continuous torque at stall	T _S	N · m	0.637
★ Peak torque at stall	T _P	N · m	2.2
★ Rated speed	N _R	min ⁻¹	3000
★ Maximum speed	N _{max}	min ⁻¹	6500
★ Rated armature current	I _R	Arms	3.8
★ Continuous armature current at stall	I _S	Arms	3.6
★ Peak armature current at stall	I _P	Arms	15.5
Torque constant	K _T	N · m/Arms	0.203
Phase resistance	R _θ	Ω	0.62
Rotor inertia	Without brake	J _M	×10 ⁻⁴ kg·m ² (GD ² /4)
	With brake		
Encoder inertia*	J _S		
★ Rated power rate	Without brake	Q _R	kW/s
	With brake		
Servo motor mass*	Without brake	W _E	kg
	With brake		
Size of heat dissipation aluminum plate	—	mm	250 × 250 × 6
Holding brake static friction torque	T _b	N·m	1.37 or greater
Holding brake rated voltage	V _b	V	24 DC ±10%
Holding brake current consumption	I _b	A	0.29
Holding brake engage time		ms	30 or less
Holding brake release time (varistor)		ms	20 or less
Holding brake release time (diode)		ms	120 or less
Compatible servo amplifier model no.	—		GADSE03 (30 A)

Speed-Torque Characteristics

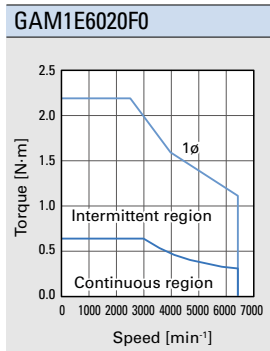

Note 1: Speed-torque characteristics curves and values in the row with a black star symbol (★) are the values after thermal equilibrium is established. All other values are at a temperature of 20°C.

Note 2: All values are typical values. Torque constant is the value when mounted on the heat dissipation aluminum plate in the table.

Note 3: The holding brake cannot be used for dynamic braking. Holding brake engage/release time denotes the delay time of holding brake activation.

Values of holding brake engage/release time vary depending on the circuit used. Please check the delay time on the actual equipment before use.

* The encoder inertia and servo motor mass values are when equipped with a battery-less absolute encoder. Contact us for more information on other encoders.

Dimensions/Options/Plug specifications Common to 60 mm sq. 200 V servo motors on p. 21



40 mm sq.

Servo motor model no.			GAM2A4003F0	GAM2A4005F0	GAM2A4010F0	GAM2A4015V0	GAM2A4015F0	
	Symbol	Unit						
★ Rated output	P _R	kW	0.03	0.05	0.10	0.15	0.15	
★ Rated torque	T _R	N · m	0.098	0.159	0.318	0.48	0.48	
★ Continuous torque at stall	T _S	N · m	0.108	0.167	0.318	0.48	0.48	
★ Peak torque at stall	T _P	N · m	0.37	0.59	1.18	1.7	1.81	
★ Rated speed	N _R	min ⁻¹	3000	3000	3000	3000	3000	
★ Maximum speed	N _{max}	min ⁻¹	6500	6500	6500	6500	6500	
★ Rated armature current	I _R	Arms	0.65	0.79	0.99	1.20	1.95	
★ Continuous armature current at stall	I _S	Arms	0.65	0.80	0.96	1.20	1.90	
★ Peak armature current at stall	I _P	Arms	2.3	2.9	3.6	4.3	7.2	
Torque constant	K _T	N · m/Arms	0.183	0.235	0.367	0.441	0.281	
Phase resistance	R _ø	Ω	10.9	9.3	9.0	8.0	3.3	
Rotor inertia	Without brake	J _M	×10 ⁻⁴ kg·m ² (GD ² /4)	0.0233	0.0324	0.0600	0.0876	0.0876
	With brake			0.0303	0.0394	0.0670	0.0946	0.0946
Encoder inertia*	J _S		0.0025	0.0025	0.0025	0.0025	0.0025	
★ Rated power rate	Without brake	Q _R	kW/s	4.1	7.8	17	26	26
	With brake			3.2	6.4	15	24	24
Servo motor mass*	Without brake	W _E	kg	0.25	0.29	0.40	0.50	0.50
	With brake			0.44	0.48	0.60	0.69	0.69
Size of heat dissipation aluminum plate	—	mm	250 × 250 × 6	250 × 250 × 6	250 × 250 × 6	305 × 305 × 12	305 × 305 × 12	
Holding brake static friction torque	T _b	N·m	0.48 or greater	0.48 or greater	0.48 or greater	0.48 or greater	0.48 or greater	
Holding brake rated voltage	V _b	V	24 DC ±10%	24 DC ±10%	24 DC ±10%	24 DC ±10%	24 DC ±10%	
Holding brake current consumption	I _b	A	0.26	0.26	0.26	0.26	0.26	
Holding brake engage time		ms	30 or less	30 or less	30 or less	30 or less	30 or less	
Holding brake release time (varistor)		ms	20 or less	20 or less	20 or less	20 or less	20 or less	
Holding brake release time (diode)		ms	100 or less	100 or less	100 or less	100 or less	100 or less	
Compatible servo amplifier model no.	—		GADSA01 (10 A)	GADSA01 (10 A)	GADSA01 (10 A)	GADSA01 (10 A)	GADSA02 (20 A)	

Speed-Torque Characteristics

3ø: When the power supply voltage is 3-phase, 1ø: When the power supply voltage is single-phase

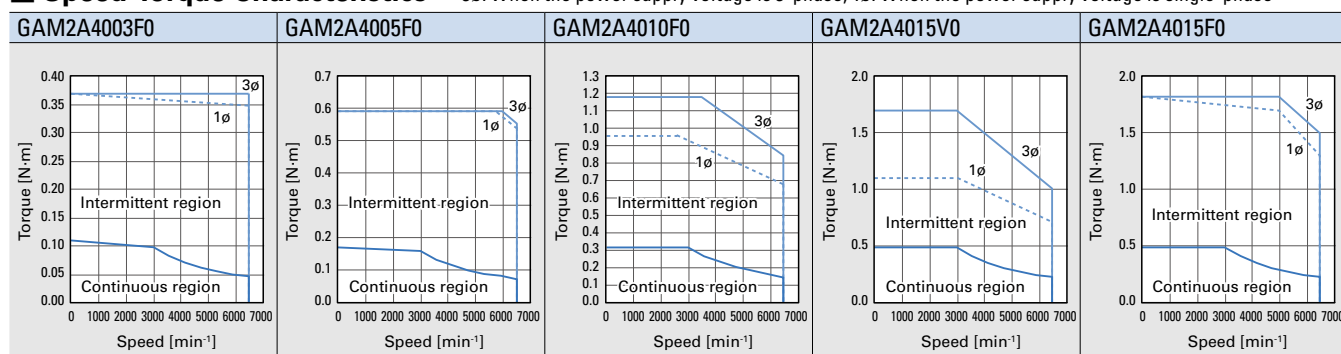

Note 1: Speed-torque characteristics curves and values in the row with a black star symbol (★) are the values after thermal equilibrium is established. All other values are at a temperature of 20°C.

Note 2: All values are typical values. Torque constant is the value when mounted on the heat dissipation aluminum plate in the table.

Note 3: The holding brake cannot be used for dynamic braking. Holding brake engage/release time denotes the delay time of holding brake activation.

Values of holding brake engage/release time vary depending on the circuit used. Please check the delay time on the actual equipment before use.

* The encoder inertia and servo motor mass values are when equipped with a battery-less absolute encoder. Contact us for more information on other encoders.

■ Dimensions [Unit: mm]

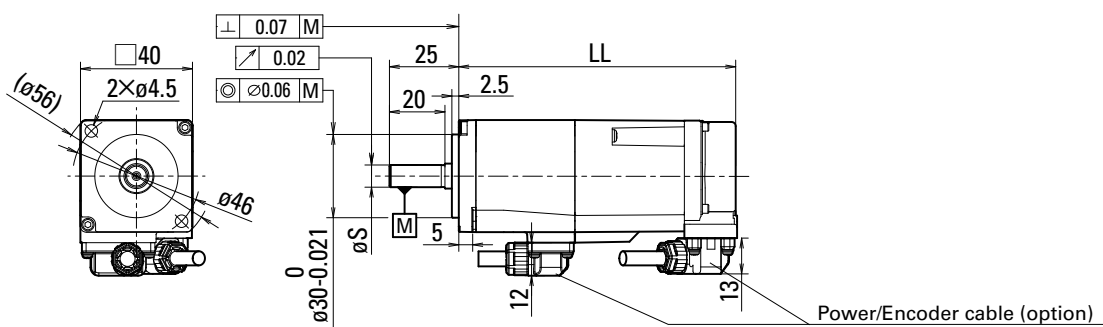

Servo motor model no.	Without oil seal		With oil seal		S
	Without brake	With brake	Without brake	With brake	
GAM2□4003	LL	LL	LL	LL	6 ⁰ _{-0.008}
GAM2□4005	51.5	84	56.5	89	8 ⁰ _{-0.009}
GAM2□4010	55.5	88	60.5	93	8 ⁰ _{-0.009}
GAM2□4015	68	100.5	73	105.5	8 ⁰ _{-0.009}
GAM2A4015	80.5	113	85.5	118	8 ⁰ _{-0.009}

Options

■ **Power/Encoder cable** Front and rear cable exits are directed to the output shaft direction and the opposite direction, respectively.

Cable model no.		Cable exit direction	Cable length [m]
Power	Encoder		
GSSF0100S	GESF0100S	Front	1
GSSR0100S	GESR0100S	Rear	1
GSSF0300S	GESF0300S	Front	3
GSSR0300S	GESR0300S	Rear	3
GSSF0500S	GESF0500S	Front	5
GSSR0500S	GESR0500S	Rear	5

Plug specifications

■ **Motor power / holding brake plug (motor side)** Manufacturer: Japan Aviation Electronics Industry, Ltd.

Cable exit direction	Plug mfr. part no.	Compatible cable diameter	Contact mfr. part no.		Compatible wire diameter (including insulation)		Compatible wire size (AWG)	
			Power	Brake	Power	Brake	Power	Brake
Front	JN16FE06SS1	ø5.2 to 5.6 mm	JN16S10K4A1		ø1.1 to 1.55 mm		22	24
Rear	JN16FE06SS2							

■ **Encoder plug (motor side)** Manufacturer: Japan Aviation Electronics Industry, Ltd.

Cable exit direction	Plug mfr. part no.	Compatible cable diameter	Contact mfr. part no.	Compatible wire diameter (including insulation)	Compatible wire size (AWG)
Front	JN16FS09SS1	ø4.9 to 5.6 mm	JN-24S-C2B-B1-10000	ø0.7 to 0.9 mm	26
Rear	JN16FS09SS2				

Note 1: Plugs and contacts are not provided. Please contact the connector manufacturer.

Note 2: See the catalogs and instruction manuals issued by the connector manufacturer (Japan Aviation Electronics Industry, Ltd.) for handling and safety precautions.

60 mm sq.

Servo motor model no.			GAM2A6010F0	GAM2A6020F0	GAM2A6040F0	GAM2A6060V0	GAM2A6060F0	
	Symbol	Unit						
★ Rated output	P _R	kW	0.1	0.2	0.4	0.6	0.6	
★ Rated torque	T _R	N · m	0.318	0.637	1.27	1.91	1.91	
★ Continuous torque at stall	T _S	N · m	0.353	0.686	1.37	2.0	2.0	
★ Peak torque at stall	T _P	N · m	1.13	2.2	4.8	7.1	7.1	
★ Rated speed	N _R	min ⁻¹	3000	3000	3000	3000	3000	
★ Maximum speed	N _{max}	min ⁻¹	6500	6500	6500	6500	6500	
★ Rated armature current	I _R	Arms	1.02	1.65	2.9	4.1	5.8	
★ Continuous armature current at stall	I _S	Arms	1.06	1.70	2.9	4.0	5.7	
★ Peak armature current at stall	I _P	Arms	3.3	5.5	10.8	15	21	
Torque constant	K _T	N · m/Arms	0.395	0.456	0.521	0.539	0.384	
Phase resistance	R _ø	Ω	5.3	2.6	1.38	0.92	0.50	
Rotor inertia	Without brake	J _M	×10 ⁻⁴ kg·m ² (GD ² /4)	0.143	0.247	0.466	0.685	0.685
	With brake			0.201	0.306	0.524	0.743	0.743
Encoder inertia*	J _S		0.0025	0.0025	0.0025	0.0025	0.0025	
★ Rated power rate	Without brake	Q _R	kW/s	7.1	16	35	53	53
	With brake			5.0	13	31	49	49
Servo motor mass*	Without brake	W _E	kg	0.59	0.80	1.3	1.6	1.6
	With brake			0.88	1.2	1.6	2.0	2.0
Size of heat dissipation aluminum plate	—	mm	250 × 250 × 6	250 × 250 × 6	250 × 250 × 6	305 × 305 × 12	305 × 305 × 12	
Holding brake static friction torque	T _b	N·m	0.36 or greater	1.37 or greater	1.37 or greater	1.91 or greater	1.91 or greater	
Holding brake rated voltage	V _b	V	24 DC ±10%	24 DC ±10%	24 DC ±10%	24 DC ±10%	24 DC ±10%	
Holding brake current consumption	I _b	A	0.27	0.29	0.29	0.32	0.32	
Holding brake engage time		ms	30 or less	30 or less	30 or less	40 or less	40 or less	
Holding brake release time (varistor)		ms	20 or less	20 or less	20 or less	20 or less	20 or less	
Holding brake release time (diode)		ms	120 or less	120 or less	120 or less	120 or less	120 or less	
Compatible servo amplifier model no.	—		GADSA01 (10 A)	GADSA02 (20 A)	GADSA02 (20 A)	GADSA03 (30 A)	GADSA05 (50 A)	

Speed-Torque Characteristics

3ø: When the power supply voltage is 3-phase, 1ø: When the power supply voltage is single-phase

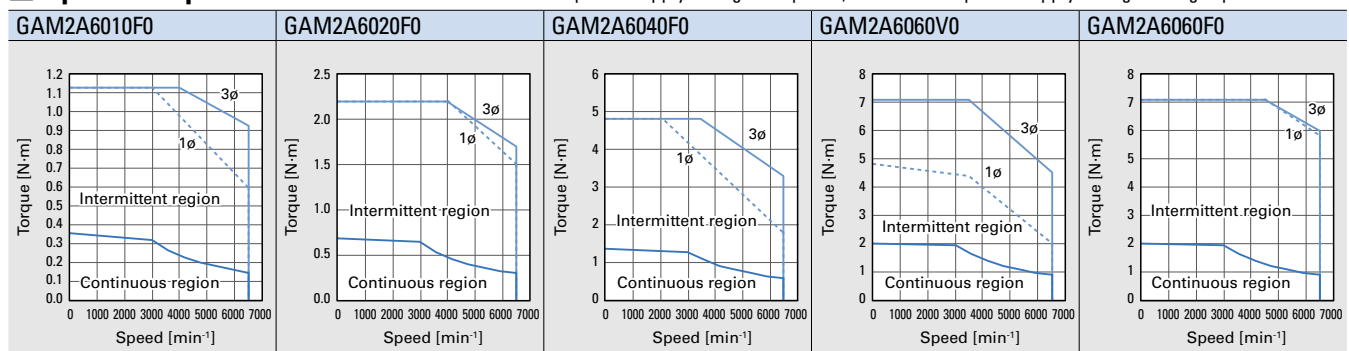

Note: GAM2A6040* and GAM2A6060* models may be derated with brake or oil seal.

Note 1: Speed-torque characteristics curves and values in the row with a black star symbol (★) are the values after thermal equilibrium is established. All other values are at a temperature of 20°C.

Note 2: All values are typical values. Torque constant is the value when mounted on the heat dissipation aluminum plate in the table.

Note 3: The holding brake cannot be used for dynamic braking. Holding brake engage/release time denotes the delay time of holding brake activation.

Values of holding brake engage/release time vary depending on the circuit used. Please check the delay time on the actual equipment before use.

* The encoder inertia and servo motor mass values are when equipped with a battery-less absolute encoder. Contact us for more information on other encoders.

■ Dimensions [Unit: mm]

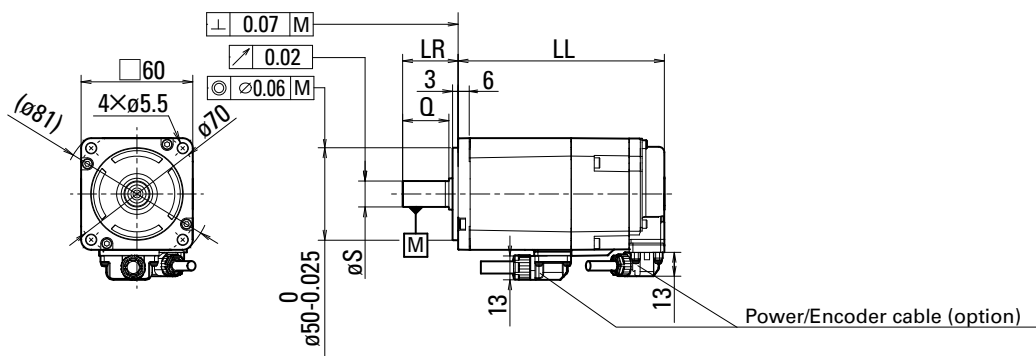

Servo motor model no.	Without oil seal		With oil seal		LR	Q	S
	Without brake	With brake	Without brake	With brake			
GAM2□6010	LL	LL	LL	LL	25	20	8 ⁰ _{-0.009}
GAM2□6020	55.5	77.5	62.5	84.5	30	25	14 ⁰ _{-0.011}
GAM2A6040	65.5	91.5	72.5	98.5	30	25	14 ⁰ _{-0.011}
GAM2A6060	85.5	111.5	92.5	118.5	30	25	14 ⁰ _{-0.011}
	115.5	143.5	122.5	150.5			

Options

■ **Power/Encoder cable** Front and rear cable exits are directed to the output shaft direction and the opposite direction, respectively.

Cable model no.		Cable exit direction	Cable length [m]
Power	Encoder		
GMSF0100S	GESF0100S	Front	1
GMSR0100S	GESR0100S	Rear	1
GMSF0300S	GESF0300S	Front	3
GMSR0300S	GESR0300S	Rear	3
GMSF0500S	GESF0500S	Front	5
GMSR0500S	GESR0500S	Rear	5

Plug specifications

■ **Motor power / holding brake plug (motor side)** Manufacturer: Japan Aviation Electronics Industry, Ltd.

Cable exit direction	Plug mfr. part no.	Compatible cable diameter	Contact mfr. part no.		Compatible wire diameter (including insulation)		Compatible wire size (AWG)	
			Power	Brake	Power	Brake	Power	Brake
Front	JN16FG06SS1	ø6.3 to 6.9 mm	JN16S25H3A1	JN16S10K4A1	ø1.2 to 1.85 mm	ø1.1 to 1.55 mm	19	23
Rear	JN16FG06SS2							

■ **Encoder plug (motor side)** Manufacturer: Japan Aviation Electronics Industry, Ltd.

Cable exit direction	Plug mfr. part no.	Compatible cable diameter	Contact mfr. part no.	Compatible wire diameter (including insulation)	Compatible wire size (AWG)
Front	JN16FS09SS1	ø4.9 to 5.6 mm	JN-24S-C2B-B1-10000	ø0.7 to 0.9 mm	26
Rear	JN16FS09SS2				

Note 1: Plugs and contacts are not provided. Please contact the connector manufacturer.

Note 2: See the catalogs and instruction manuals issued by the connector manufacturer (Japan Aviation Electronics Industry, Ltd.) for handling and safety precautions.



80 mm sq.

Servo motor model no.			GAM2A8020F0	GAM2A8040F0	GAM2A8075V0	GAM2A8075F0	GAM2A8100F0	
	Symbol	Unit						
★ Rated output	P _R	kW	0.2	0.4	0.75	0.75	1.0	
★ Rated torque	T _R	N · m	0.637	1.27	2.39	2.39	3.18	
★ Continuous torque at stall	T _S	N · m	0.686	1.37	2.55	2.55	3.39	
★ Peak torque at stall	T _P	N · m	2.2	4.4	8.5	8.5	11.3	
★ Rated speed	N _R	min ⁻¹	3000	3000	3000	3000	3000	
★ Maximum speed	N _{max}	min ⁻¹	6500	6500	6500	6500	6500	
★ Rated armature current	I _R	Arms	1.53	2.8	4.3	5.9	6.2	
★ Continuous armature current at stall	I _S	Arms	1.59	2.9	4.4	5.9	6.3	
★ Peak armature current at stall	I _P	Arms	5.8	9.7	16	21.4	23	
Torque constant	K _T	N · m/Arms	0.476	0.530	0.625	0.464	0.579	
Phase resistance	R _ø	Ω	2.9	1.25	0.65	0.38	0.45	
Rotor inertia	Without brake	J _M	×10 ⁻⁴ kg·m ² (GD ² /4)	0.409	0.805	1.56	1.56	1.96
	With brake			0.596	0.992	1.76	1.76	2.16
Encoder inertia*	J _S		0.0025	0.0025	0.0025	0.0025	0.0025	
★ Rated power rate	Without brake	Q _R	kW/s	9.9	20	37	37	52
	With brake			6.8	16	32	32	47
Servo motor mass*	Without brake	W _E	kg	1.2	1.5	2.2	2.2	2.5
	With brake			1.8	2.1	3.0	3.0	3.3
Size of heat dissipation aluminum plate	—	mm	250 × 250 × 6	250 × 250 × 6	250 × 250 × 6	250 × 250 × 6	305 × 305 × 12	
Holding brake static friction torque	T _b	N·m	1.37 or greater	1.37 or greater	3.18 or greater	3.18 or greater	3.18 or greater	
Holding brake rated voltage	V _b	V	24 DC ±10%	24 DC ±10%	24 DC ±10%	24 DC ±10%	24 DC ±10%	
Holding brake current consumption	I _b	A	0.32	0.32	0.33	0.33	0.33	
Holding brake engage time		ms	50 or less	50 or less	50 or less	50 or less	50 or less	
Holding brake release time (varistor)		ms	30 or less	30 or less	30 or less	30 or less	30 or less	
Holding brake release time (diode)		ms	200 or less	200 or less	200 or less	200 or less	200 or less	
Compatible servo amplifier model no.	—		GADSA02 (20 A)	GADSA02 (20 A)	GADSA03 (30 A)	GADSA05 (50 A)	GADSA05 (50 A)	

Speed-Torque Characteristics

3ø: When the power supply voltage is 3-phase, 1ø: When the power supply voltage is single-phase

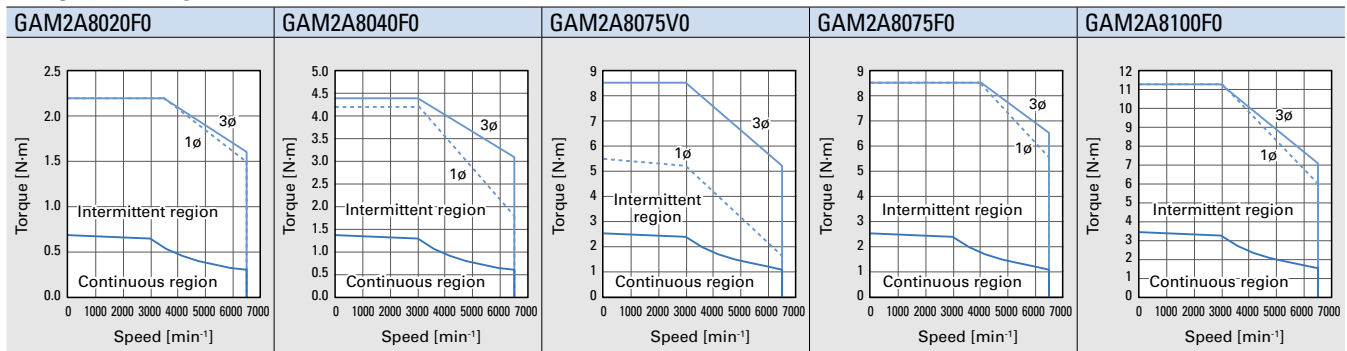

Note: GAM2A8075* and GAM2A8100* models may be derated with brake or oil seal.

Note 1: Speed-torque characteristics curves and values in the row with a black star symbol (★) are the values after thermal equilibrium is established. All other values are at a temperature of 20°C.

Note 2: All values are typical values. Torque constant is the value when mounted on the heat dissipation aluminum plate in the table.

Note 3: The holding brake cannot be used for dynamic braking. Holding brake engage/release time denotes the delay time of holding brake activation.

Values of holding brake engage/release time vary depending on the circuit used. Please check the delay time on the actual equipment before use.

* The encoder inertia and servo motor mass values are when equipped with a battery-less absolute encoder. Contact us for more information on other encoders.

■ Dimensions [Unit: mm]

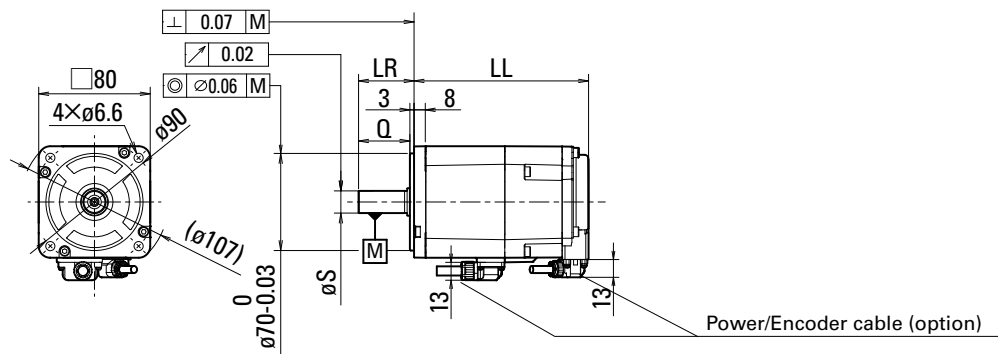

Servo motor model no.	Without oil seal		With oil seal		LR	Q	S
	Without brake	With brake	Without brake	With brake			
GAM2□8020	63	86.5	70	93.5	30	25	14 ⁰ _{-0.011}
GAM2□8040	72.5	96.5	79.5	103.5	30	25	14 ⁰ _{-0.011}
GAM2□8075	92	126	99	133	40	35	16 ⁰ _{-0.011}
GAM2□8100	102	135.5	109	142.5	40	35	16 ⁰ _{-0.011}

Options

■ **Power/Encoder cable** Front and rear cable exits are directed to the output shaft direction and the opposite direction, respectively.

Cable model no.		Cable exit direction	Cable length [m]
Power	Encoder		
GMSF0100S	GESF0100S	Front	1
GMSR0100S	GESR0100S	Rear	1
GMSF0300S	GESF0300S	Front	3
GMSR0300S	GESR0300S	Rear	3
GMSF0500S	GESF0500S	Front	5
GMSR0500S	GESR0500S	Rear	5

Plug specifications

■ **Motor power / holding brake plug (motor side)** Manufacturer: Japan Aviation Electronics Industry, Ltd.

Cable exit direction	Plug mfr. part no.	Compatible cable diameter	Contact mfr. part no.		Compatible wire diameter (including insulation)		Compatible wire size (AWG)	
			Power	Brake	Power	Brake	Power	Brake
Front	JN16FG06SS1	ø6.3 to 6.9 mm	JN16S25H3A1	JN16S10K4A1	ø1.2 to 1.85 mm	ø1.1 to 1.55 mm	19	23
Rear	JN16FG06SS2							

■ **Encoder plug (motor side)** Manufacturer: Japan Aviation Electronics Industry, Ltd.

Cable exit direction	Plug mfr. part no.	Compatible cable diameter	Contact mfr. part no.	Compatible wire diameter (including insulation)	Compatible wire size (AWG)
Front	JN16FS09SS1	ø4.9 to 5.6 mm	JN-24S-C2B-B1-10000	ø0.7 to 0.9 mm	26
Rear	JN16FS09SS2				

Note 1: Plugs and contacts are not provided. Please contact the connector manufacturer.

Note 2: See the catalogs and instruction manuals issued by the connector manufacturer (Japan Aviation Electronics Industry, Ltd.) for handling and safety precautions.

86 mm sq.

Servo motor model no.			GAM2A9075F0	GAM2A9100H0	GAM2A9100F0	
	Symbol	Unit				
★ Rated output	P _R	kW	0.75	1.0	1.0	
★ Rated torque	T _R	N·m	2.38	3.18	3.18	
★ Continuous torque at stall	T _S	N·m	2.94	3.92	3.92	
★ Peak torque at stall	T _P	N·m	11.0	11.6	14.3	
★ Rated speed	N _R	min ⁻¹	3000	3000	3000	
★ Maximum speed	N _{max}	min ⁻¹	6500	3000	6500	
★ Rated armature current	I _R	Arms	4.7	4.6	6.0	
★ Continuous armature current at stall	I _S	Arms	5.5	4.7	6.8	
★ Peak armature current at stall	I _P	Arms	23.5	15.5	25.7	
Torque constant	K _T	N·m/Arms	0.547	0.825	0.582	
Phase resistance	R _∅	Ω	0.62	0.85	0.44	
Rotor inertia	Without brake	J _M	×10 ⁻⁴ kg·m ² (GD ² /4)	1.57	2.45	2.45
	With brake			1.87	2.75	2.75
Encoder inertia*	J _S		0.0025	0.0025	0.0025	
★ Rated power rate	Without brake	Q _R	kW/s	36	41	41
	With brake			30	37	37
Servo motor mass*	Without brake	W _E	kg	2.7	3.4	3.4
	With brake			3.5	4.2	4.2
Size of heat dissipation aluminum plate	—	mm	305 × 305 × 12	305 × 305 × 12	305 × 305 × 12	
Holding brake static friction torque	T _b	N·m	3.92 or greater	3.92 or greater	3.92 or greater	
Holding brake rated voltage	V _b	V	24 DC ± 10%	24 DC ± 10%	24 DC ± 10%	
Holding brake current consumption	I _b	A	0.34	0.34	0.34	
Holding brake engage time		ms	50 or less	50 or less	50 or less	
Holding brake release time (varistor)		ms	30 or less	30 or less	30 or less	
Holding brake release time (diode)		ms	200 or less	200 or less	200 or less	
Compatible servo amplifier model no.	—		GADSA05 (50 A)	GADSA03 (30 A)	GADSA05 (50 A)	

Speed-Torque Characteristics

3∅: When the power supply voltage is 3-phase, 1∅: When the power supply voltage is single-phase (the rated output of GAM2A9100H0 is 750 W)

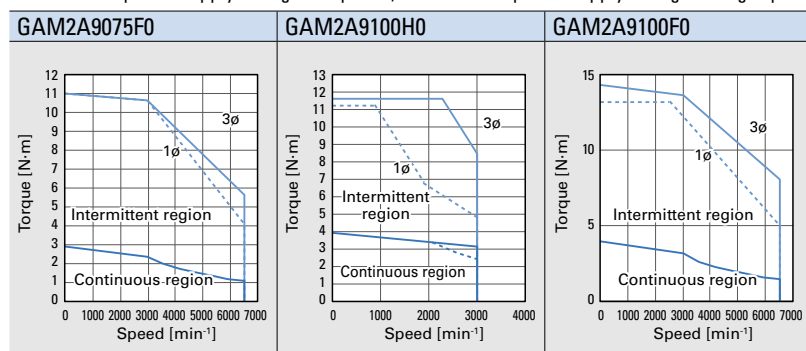

Note: GAM2A9100* models may be derated with brake or oil seal.

Note 1: Speed-torque characteristics curves and values in the row with a black star symbol (★) are the values after thermal equilibrium is established. All other values are at a temperature of 20°C.

Note 2: All values are typical values. Torque constant is the value when mounted on the heat dissipation aluminum plate in the table.

Note 3: The holding brake cannot be used for dynamic braking. Holding brake engage/release time denotes the delay time of holding brake activation.

Values of holding brake engage/release time vary depending on the circuit used. Please check the delay time on the actual equipment before use.

* The encoder inertia and servo motor mass values are when equipped with a battery-less absolute encoder. Contact us for more information on other encoders.

■ Dimensions [Unit: mm] The LL value does not change with or without oil seal.

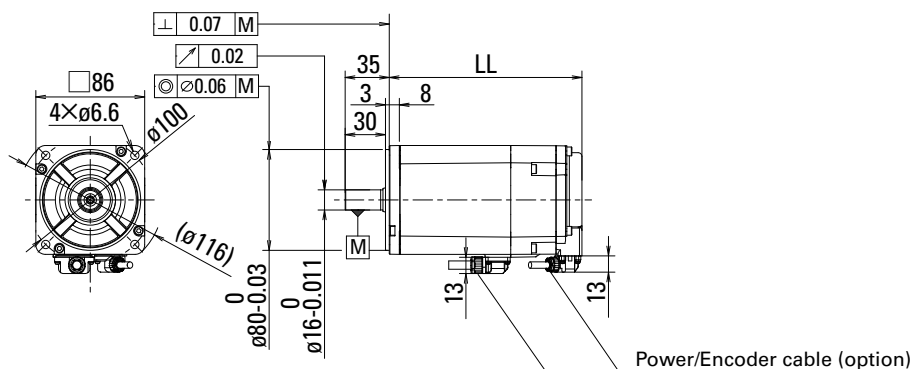

	Without brake	With brake
Servo motor model no.	LL	LL
GAM2□9075	104.5	130
GAM2□9100	127	153

Options

■ Power/Encoder cable

Front and rear cable exits are directed to the output shaft direction and the opposite direction, respectively.

Cable model no.		Cable exit direction	Cable length [m]
Power	Encoder		
GMSF0100S	GESF0100S	Front	1
GMSR0100S	GESR0100S	Rear	1
GMSF0300S	GESF0300S	Front	3
GMSR0300S	GESR0300S	Rear	3
GMSF0500S	GESF0500S	Front	5
GMSR0500S	GESR0500S	Rear	5

Plug specifications

■ Motor power / holding brake plug (motor side)

Manufacturer: Japan Aviation Electronics Industry, Ltd.

Cable exit direction	Plug mfr. part no.	Compatible cable diameter	Contact mfr. part no.		Compatible wire diameter (including insulation)		Compatible wire size (AWG)	
			Power	Brake	Power	Brake	Power	Brake
Front	JN16FG06SS1	ø6.3 to 6.9 mm	JN16S25H3A1	JN16S10K4A1	ø1.2 to 1.85 mm	ø1.1 to 1.55 mm	19	23
Rear	JN16FG06SS2							

■ Encoder plug (motor side)

Manufacturer: Japan Aviation Electronics Industry, Ltd.

Cable exit direction	Plug mfr. part no.	Compatible cable diameter	Contact mfr. part no.	Compatible wire diameter (including insulation)	Compatible wire size (AWG)
Front	JN16FS09SS1	ø4.9 to 5.6 mm	JN-24S-C2B-B1-10000	ø0.7 to 0.9 mm	26
Rear	JN16FS09SS2				

Note 1: Plugs and contacts are not provided. Please contact the connector manufacturer.

Note 2: See the catalogs and instruction manuals issued by the connector manufacturer (Japan Aviation Electronics Industry, Ltd.) for handling and safety precautions.



100 mm sq.

Servo motor model no.			GAM2AA075F0	GAM2AA100F0	GAM2AA150H0	GAM2AA150F0	
	Symbol	Unit					
★ Rated output	P _R	kW	0.75	1.0	1.5	1.5	
★ Rated torque	T _R	N·m	2.39	3.18	7.2	4.8	
★ Continuous torque at stall	T _S	N·m	2.55	3.92	8.0	4.9	
★ Peak torque at stall	T _P	N·m	8.7	14.7	21.0	14.7	
★ Rated speed	N _R	min ⁻¹	3000	3000	2000	3000	
★ Maximum speed	N _{max}	min ⁻¹	6000	6000	3000	6000	
★ Rated armature current	I _R	Arms	4.5	5.5	8.3	8.6	
★ Continuous armature current at stall	I _S	Arms	4.6	6.2	8.9	8.5	
★ Peak armature current at stall	I _P	Arms	16.3	26.5	25.5	26.5	
Torque constant	K _T	N·m/Arms	0.639	0.665	0.983	0.633	
Phase resistance	R _φ	Ω	0.69	0.32	0.43	0.16	
Rotor inertia	Without brake	J _M	×10 ⁻⁴ kg·m ² (GD ² /4)	2.36	3.97	6.10	6.10
	With brake			2.69	4.30	6.45	6.45
Encoder inertia*	J _S		0.0025	0.0025	0.0025	0.0025	
★ Rated power rate	Without brake	Q _R	kW/s	24	25	85	38
	With brake			21	24	80	36
Servo motor mass*	Without brake	W _E	kg	3.3	4.1	5.9	5.9
	With brake			4.1	4.9	7.5	7.5
Size of heat dissipation aluminum plate	—	mm	305 × 305 × 12	305 × 305 × 12	400 × 400 × 20	400 × 400 × 20	
Holding brake static friction torque	T _b	N·m	3.92 or greater	3.92 or greater	8 or greater	8 or greater	
Holding brake rated voltage	V _b	V	24 DC ± 10%	24 DC ± 10%	24 DC ± 10%	24 DC ± 10%	
Holding brake current consumption	I _b	A	0.36	0.36	0.67	0.67	
Holding brake engage time		ms	50 or less	50 or less	100 or less	100 or less	
Holding brake release time (varistor)		ms	30 or less	30 or less	30 or less	30 or less	
Holding brake release time (diode)		ms	200 or less	200 or less	200 or less	200 or less	
Compatible servo amplifier model no.	—		GADSA03 (30 A)	GADSA05 (50 A)	GADSA05 (50 A)	GADSA05 (50 A)	

Speed-Torque Characteristics

3φ: When the power supply voltage is 3-phase, 1φ: When the power supply voltage is single-phase

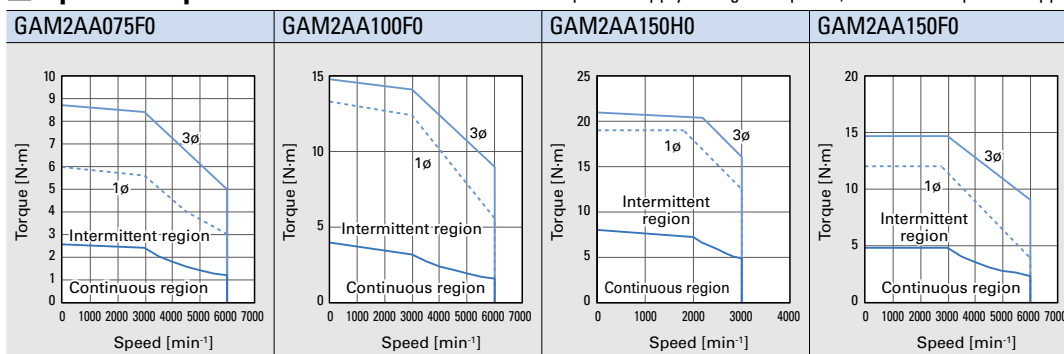

Note 1: Speed-torque characteristics curves and values in the row with a black star symbol (★) are the values after thermal equilibrium is established. All other values are at a temperature of 20°C.

Note 2: All values are typical values. Torque constant is the value when mounted on the heat dissipation aluminum plate in the table.

Note 3: The holding brake cannot be used for dynamic braking. Holding brake engage/release time denotes the delay time of holding brake activation.

Values of holding brake engage/release time vary depending on the circuit used. Please check the delay time on the actual equipment before use.

* The encoder inertia and servo motor mass values are when equipped with a battery-less absolute encoder. Contact us for more information on other encoders.

■ Dimensions [Unit: mm] The LL value does not change with or without oil seal.

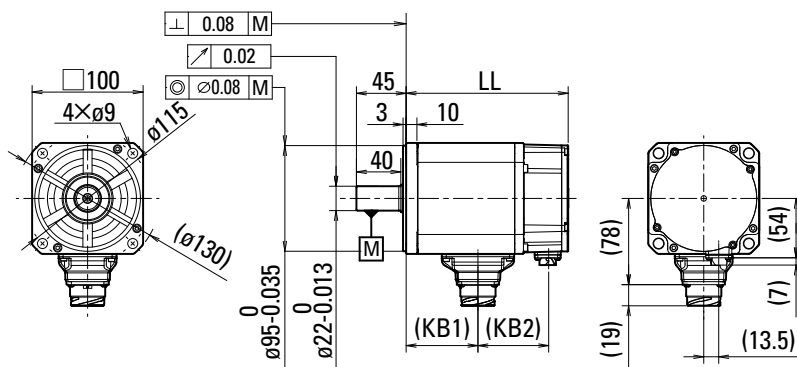

Servo motor model no.	Without brake		With brake		Without brake		With brake	
	LL	LL	KB1	KB2	KB1	KB2	KB1	KB2
GAM2□A075	111	129	47.5	45	47.5	63		
GAM2□A100	128	146	64.5	45	64.5	63		
GAM2□A150	161	205.5	97.5	45	97.5	90		

Options

■ Power/Encoder cable

Cable model no.			Cable length [m]
Power (without brake)	Power (with brake)	Encoder	
GPPB0100S	GQPB0100SB	RS-CA9-01-R	1
GPPB0300S	GQPB0300SB	RS-CA9-03-R	3
GPPB0500S	GQPB0500SB	RS-CA9-05-R	5

Plug specifications

■ Motor power / holding brake plug (motor side) Manufacturer: Japan Aviation Electronics Industry, Ltd.

Holding brake	Receptacle mfr. part no.	Pin assignment					Recommended motor power cable size (U, V, W, and ground)	
		U phase	V phase	W phase	Ground	Brake	mm ²	AWG No.
None	JL10-2E20-4PE-B	A	B	C	D	—	2.0	14
Yes	JL10-2E20-18PE-B	F	I	B	E, D	G, H	2.0	14

Holding brake	Plug mfr. part no.		Cable clamp	
	Straight	Angled	Mfr. part no.	Compatible cable outer diameter
None	JL10-6A20-4SE-EB	JL10-8A20-4SE-EB	JL04V-2022CK(14)-R	ø12.9 to 16 mm
Yes	JL10-6A20-18SE-EB	JL10-8A20-18SE-EB	JL04V-2022CK(14)-R	ø12.9 to 16 mm

■ Encoder plug (motor side) Manufacturer: Japan Aviation Electronics Industry, Ltd.

Receptacle mfr. part no.	Plug mfr. part no.		Compatible cable diameter	Contact size	Classification	Applicable socket contact	
	Straight	Angled				Mfr. part no.	Compatible wire size
JN2AS10ML2-R	JN2DS10SL1-R	JN2FS10SL1-R	ø5.7 to 7.3 mm	#22	Manual crimping tool type	JN1-22-20S-R-PKG100	AWG 20
	JN2DS10SL2-R	JN2FS10SL2-R	ø6.5 to 8.0 mm			JN1-22-22S-PKG100	AWG 25 to 21
	JN2DS10SL3-R	JN2FS10SL3-R	ø3.5 to 5.0 mm			JN1-22-26S-PKG100	AWG 28 to 26
					Soldering type	JN1-22-22F-PKG100	AWG 20 or smaller

Note: See the catalogs and instruction manuals issued by the connector manufacturer (Japan Aviation Electronics Industry, Ltd.) for handling and safety precautions.



130 mm sq.

Servo motor model no.			GAM2AB055D0	GAM2AB120B0	GAM2AB120H0	GAM2AB120D0	
	Symbol	Unit					
★ Rated output	P _R	kW	0.55	1.2	1.2	1.2	
★ Rated torque	T _R	N · m	2.6	5.8	5.8	5.8	
★ Continuous torque at stall	T _S	N · m	3.0	6.0	6.0	6.0	
★ Peak torque at stall	T _P	N · m	9.0	16.5	20.0	16.5	
★ Rated speed	N _R	min ⁻¹	2000	2000	2000	2000	
★ Maximum speed	N _{max}	min ⁻¹	5000	3000	4000	5000	
★ Rated armature current	I _R	Arms	4.3	5.2	6.7	8.7	
★ Continuous armature current at stall	I _S	Arms	4.7	5.2	6.6	8.6	
★ Peak armature current at stall	I _P	Arms	16.3	15.5	26.5	26.0	
Torque constant	K _T	N · m/Arms	0.702	1.26	0.971	0.756	
Phase resistance	R _φ	Ω	0.64	0.71	0.40	0.24	
Rotor inertia	Without brake	J _M	×10 ⁻⁴ kg·m ² (GD ² /4)	4.36	7.78	7.78	7.78
	With brake			5.43	8.86	8.86	8.86
Encoder inertia*	J _S		0.0025	0.0025	0.0025	0.0025	
★ Rated power rate	Without brake	Q _R	kW/s	16	43	43	43
	With brake			12	38	38	38
Servo motor mass*	Without brake	W _E	kg	4.2	5.5	5.5	5.5
	With brake			5.8	7.1	7.1	7.1
Size of heat dissipation aluminum plate	—	mm	305 × 305 × 20	400 × 400 × 20	400 × 400 × 20	400 × 400 × 20	
Holding brake static friction torque	T _b	N·m	13 or greater	13 or greater	13 or greater	13 or greater	
Holding brake rated voltage	V _b	V	24 DC ±10%	24 DC ±10%	24 DC ±10%	24 DC ±10%	
Holding brake current consumption	I _b	A	0.39	0.39	0.39	0.39	
Holding brake engage time		ms	100 or less	100 or less	100 or less	100 or less	
Holding brake release time (varistor)		ms	30 or less	30 or less	30 or less	30 or less	
Holding brake release time (diode)		ms	200 or less	200 or less	200 or less	200 or less	
Compatible servo amplifier model no.	—		GADSA03 (30 A)	GADSA03 (30 A)	GADSA05 (50 A)	GADSA05 (50 A)	

Speed-Torque Characteristics

3φ: When the power supply voltage is 3-phase, 1φ: When the power supply voltage is single-phase (the rated output of GAM2AB120B0 is 750 W)

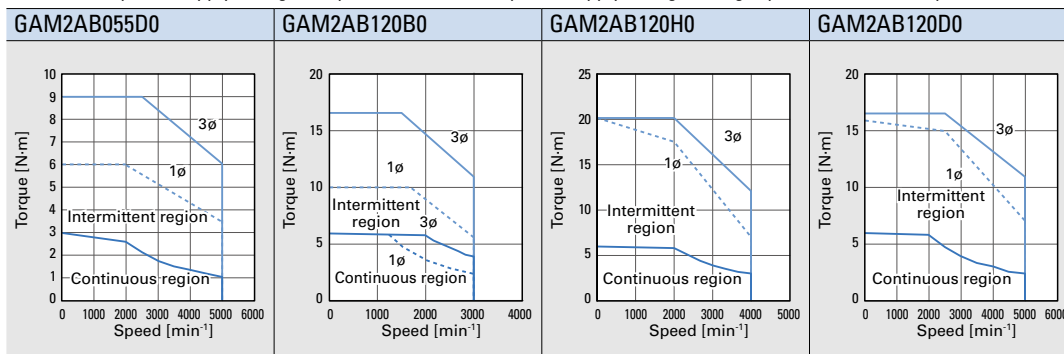

Note 1: Speed-torque characteristics curves and values in the row with a black star symbol (★) are the values after thermal equilibrium is established. All other values are at a temperature of 20°C.

Note 2: All values are typical values. Torque constant is the value when mounted on the heat dissipation aluminum plate in the table.

Note 3: The holding brake cannot be used for dynamic braking. Holding brake engage/release time denotes the delay time of holding brake activation.

Values of holding brake engage/release time vary depending on the circuit used. Please check the delay time on the actual equipment before use.

* The encoder inertia and servo motor mass values are when equipped with a battery-less absolute encoder. Contact us for more information on other encoders.

■ Dimensions [Unit: mm] The LL value does not change with or without oil seal.

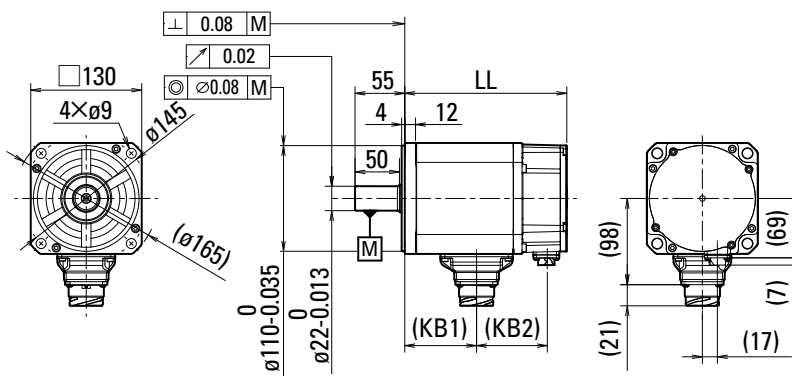

Servo motor model no.	Without brake	With brake	Without brake		With brake	
	LL	LL	KB1	KB2	KB1	KB2
GAM2□B055	96.5	121.5	42.5	35	42.5	59
GAM2□B120	110.5	135.5	56.5	35	56.5	59

Options

■ Power/Encoder cable

Power (without brake)	Cable model no.		Encoder	Cable length [m]
	Power (with brake)			
GRPB0100S	GRPB0100SB		RS-CA9-01-R	1
GRPB0300S	GRPB0300SB		RS-CA9-03-R	3
GRPB0500S	GRPB0500SB		RS-CA9-05-R	5

Plug specifications

■ Motor power / holding brake plug (motor side) Manufacturer: Japan Aviation Electronics Industry, Ltd.

Holding brake	Receptacle mfr. part no.	Pin assignment					Recommended motor power cable size (U, V, W, and ground)	
		U phase	V phase	W phase	Ground	Brake	mm ²	AWG No.
None	JL10-2E24-11PE-B	D	E	F	G, H	—	2.0	14
Yes	JL10-2E24-11PE-B	D	E	F	G, H	A, B	2.0	14

Holding brake	Plug mfr. part no.		Cable clamp	
	Straight	Angled	Mfr. part no.	Compatible cable outer diameter
None/Yes	JL10-6A24-11SE-EB	JL10-8A24-11SE-EB	JL04V-2428CK(17)-R	ø15 to 18 mm

■ Encoder plug (motor side) Manufacturer: Japan Aviation Electronics Industry, Ltd.

Receptacle Mfr. part no.	Plug mfr. part no.		Compatible cable diameter	Contact size	Classification	Applicable socket contact	
	Straight	Angled				Mfr. part no.	Compatible wire size
JN2AS10ML2-R	JN2DS10SL1-R	JN2FS10SL1-R	ø5.7 to 7.3 mm	#22	Manual crimping tool type	JN1-22-20S-R-PKG100	AWG 20
	JN2DS10SL2-R	JN2FS10SL2-R	ø6.5 to 8.0 mm			JN1-22-22S-PKG100	AWG 25 to 21
	JN2DS10SL3-R	JN2FS10SL3-R	ø3.5 to 5.0 mm			JN1-22-26S-PKG100	AWG 28 to 26
					Soldering type	JN1-22-22F-PKG100	AWG 20 or smaller

Note: See the catalogs and instruction manuals issued by the connector manufacturer (Japan Aviation Electronics Industry, Ltd.) for handling and safety precautions.

40 mm sq.

Servo motor model no.			GAM2E4003F0	GAM2E4005F0	GAM2E4010F0	
	Symbol	Unit				
★ Rated output	P _R	kW	0.03	0.05	0.1	
★ Rated torque	T _R	N · m	0.098	0.159	0.318	
★ Continuous torque at stall	T _S	N · m	0.108	0.167	0.318	
★ Peak torque at stall	T _P	N · m	0.37	0.59	1.18	
★ Rated speed	N _R	min ⁻¹	3000	3000	3000	
★ Maximum speed	N _{max}	min ⁻¹	6500	6500	6500	
★ Rated armature current	I _R	Arms	1.00	1.62	1.98	
★ Continuous armature current at stall	I _S	Arms	1.00	1.58	1.92	
★ Peak armature current at stall	I _P	Arms	3.5	5.8	7.2	
Torque constant	K _T	N · m/Arms	0.123	0.117	0.183	
Phase resistance	R _ø	Ω	4.5	2.33	2.25	
Rotor inertia	Without brake	J _M	×10 ⁻⁴ kg·m ² (GD ² /4)	0.0233	0.0324	0.0600
	With brake			0.0303	0.0394	0.0670
Encoder inertia*	J _S		0.0025	0.0025	0.0025	
★ Rated power rate	Without brake	Q _R	kW/s	4.1	7.8	17
	With brake			3.2	6.4	15
Servo motor mass*	Without brake	W _E	kg	0.25	0.29	0.40
	With brake			0.44	0.48	0.60
Size of heat dissipation aluminum plate	—	mm	250 × 250 × 6	250 × 250 × 6	250 × 250 × 6	
Holding brake static friction torque	T _b	N·m	0.48	0.48	0.48	
Holding brake rated voltage	V _b	V	24 DC ±10%	24 DC ±10%	24 DC ±10%	
Holding brake current consumption	I _b	A	0.26	0.26	0.26	
Holding brake engage time		ms	30 or less	30 or less	30 or less	
Holding brake release time (varistor)		ms	20 or less	20 or less	20 or less	
Holding brake release time (diode)		ms	100 or less	100 or less	100 or less	
Compatible servo amplifier model no.	—		GADSE01 (10 A)	GADSE02 (20 A)	GADSE02 (20 A)	

Speed-Torque Characteristics

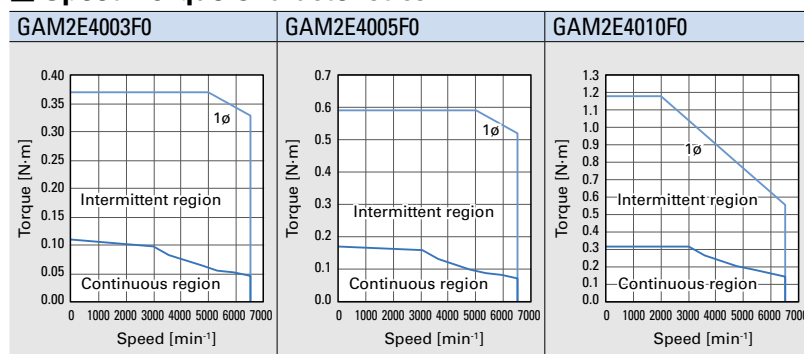

Note 1: Speed-torque characteristics curves and values in the row with a black star symbol (★) are the values after thermal equilibrium is established. All other values are at a temperature of 20°C.

Note 2: All values are typical values. Torque constant is the value when mounted on the heat dissipation aluminum plate in the table.

Note 3: The holding brake cannot be used for dynamic braking. Holding brake engage/release time denotes the delay time of holding brake activation.

Values of holding brake engage/release time vary depending on the circuit used. Please check the delay time on the actual equipment before use.

* The encoder inertia and servo motor mass values are when equipped with a battery-less absolute encoder. Contact us for more information on other encoders.

Dimensions/Options/Plug specifications Common to 40 mm sq. 200 V servo motors on p. 29

60 mm sq.

Servo motor model no.			GAM2E6010F0	GAM2E6020F0
	Symbol	Unit		
★ Rated output	P _R	kW	0.1	0.2
★ Rated torque	T _R	N · m	0.318	0.637
★ Continuous torque at stall	T _S	N · m	0.318	0.686
★ Peak torque at stall	T _P	N · m	1.0	2.2
★ Rated speed	N _R	min ⁻¹	3000	3000
★ Maximum speed	N _{max}	min ⁻¹	6500	6500
★ Rated armature current	I _R	Arms	2.05	3.3
★ Continuous armature current at stall	I _S	Arms	1.97	3.4
★ Peak armature current at stall	I _P	Arms	5.8	11.1
Torque constant	K _T	N · m/Arms	0.197	0.228
Phase resistance	R _ø	Ω	1.33	0.66
Rotor inertia	Without brake	J _M	×10 ⁻⁴ kg·m ² (GD ² /4)	0.143
	With brake			0.201
Encoder inertia*	J _S		0.0025	0.0025
★ Rated power rate	Without brake	Q _R	kW/s	7.1
	With brake			5.0
Servo motor mass*	Without brake	W _E	kg	0.59
	With brake			0.88
Size of heat dissipation aluminum plate	—	mm	250 × 250 × 6	250 × 250 × 6
Holding brake static friction torque	T _b	N·m	0.36 or greater	1.37 or greater
Holding brake rated voltage	V _b	V	24 DC ±10%	24 DC ±10%
Holding brake current consumption	I _b	A	0.27	0.29
Holding brake engage time		ms	30 or less	30 or less
Holding brake release time (varistor)		ms	20 or less	20 or less
Holding brake release time (diode)		ms	120 or less	120 or less
Compatible servo amplifier model no.	—		GADSE02 (20 A)	GADSE03 (30 A)

Speed-Torque Characteristics

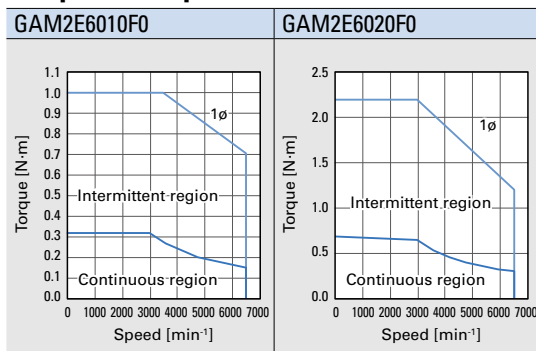

Note 1: Speed-torque characteristics curves and values in the row with a black star symbol (★) are the values after thermal equilibrium is established. All other values are at a temperature of 20°C.

Note 2: All values are typical values. Torque constant is the value when mounted on the heat dissipation aluminum plate in the table.

Note 3: The holding brake cannot be used for dynamic braking. Holding brake engage/release time denotes the delay time of holding brake activation.

Values of holding brake engage/release time vary depending on the circuit used. Please check the delay time on the actual equipment before use.

* The encoder inertia and servo motor mass values are when equipped with a battery-less absolute encoder. Contact us for more information on other encoders.

Dimensions/Options/Plug specifications

Common to 60 mm sq. 200 V servo motors on p. 31

Servo motor specification

Motor duty rating	Continuous
Thermal class	F
Dielectric strength	100 VAC power supply: 1500 VAC for 1 min 200 VAC power supply: 1500 VAC for 1 min
Insulation resistance	10 MΩ min. at 500 VDC
Protection	Totally Enclosed Non-Ventilated
Operating ambient temperature	0 to 40°C
Storage temperature	-20 to 65°C (non-freezing)
Operating and storage humidity	20 to 90% (non-condensing)
Operating altitude	2000 m max.*
Vibration class	V15
Excitation system	Permanent magnet
Mounting	Flange
Installation locations	Indoors (not exposed to direct sunlight) A location free of corrosive gases, flammable gases, powder dust, and other substances that are detrimental to the used machines and motors.
Protection rating	IP67

*When used in environments above 1000 m in altitude, derating may be required. Please contact us for limitations such as continuous rating.

Signal names and pin numbers of servo motor and encoder

(Common to analog/pulse and EtherCAT types)

Battery-less absolute encoder

Single-turn absolute encoder

Servo amplifier connector X3 or X4		Servo motor			
Terminal no. (Plug pin no.)	Signal name	For 40 to 86 mm sq. motors (Plug pin no.)	For 100 to 130 mm sq. motors (Plug pin no.)	Description	Remarks ⁽¹⁾
1	5V	2	9	Power supply	Twisted pair (Recommended)
2	SG	3	10	Common power supply	
3	–	–	–	–	–
4	–	–	–	–	–
5	(NC)	–	–	No connection ⁽³⁾	–
6	(NC)	–	–	No connection ⁽³⁾	–
7	ES+	6	1	Serial communication signal	Twisted pair
8	ES-	7	2		
9	(NC)	–	–	No connection ⁽³⁾	–
10	(NC)	–	–	No connection ⁽³⁾	–
⁽²⁾	Ground	1	7	Shielded	–

(1) Use shielded twisted pair cables.

(2) Connect the shielded cables to the metal case (ground) of the encoder connectors (X3, X4) of the servo amplifier and the ground of the motor encoder, respectively.

(3) Please make sure to leave pins 5, 6, 9, and 10 unconnected.

Note: Contact us if the cable length is to be longer than 10 m and 25 m for 40 to 86 mm sq. models and 100 to 130 mm sq. models, respectively.
Contact us for more information on other encoders.

Linear Servo Motors

Flat type with core

Center magnet type with core



How to read model numbers

Note that not all possible combinations of field values may yield valid products. Also, some of the values listed below are for options.

Coil

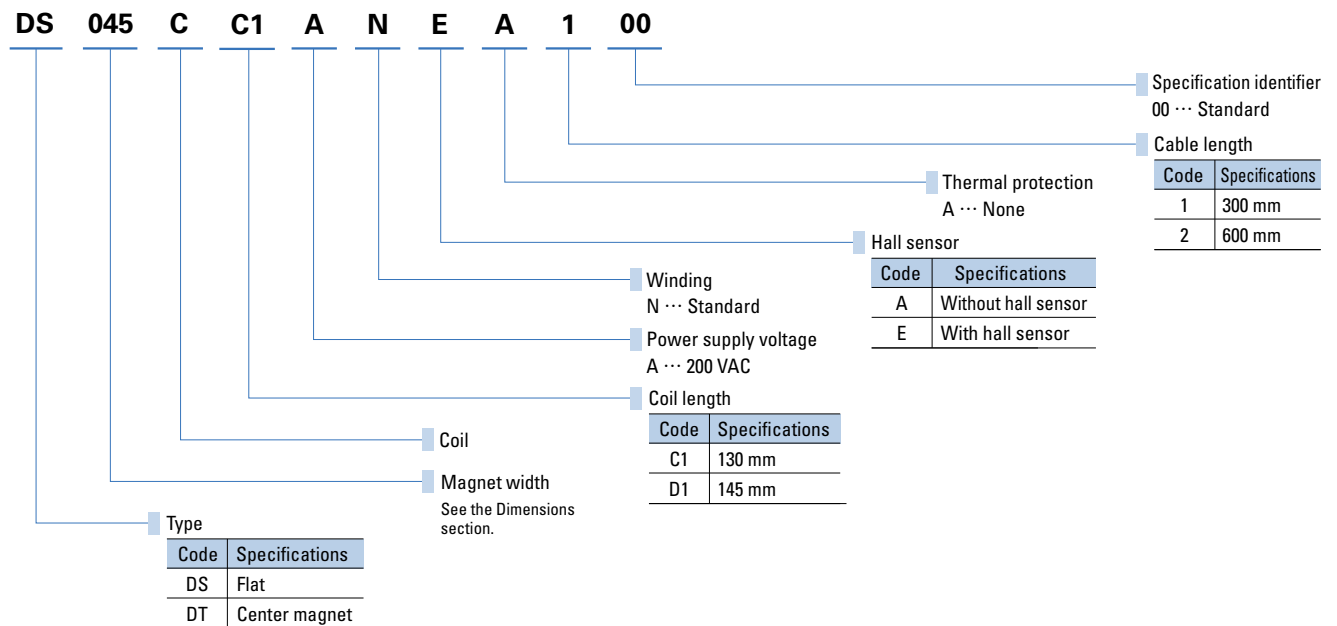

Magnet rail

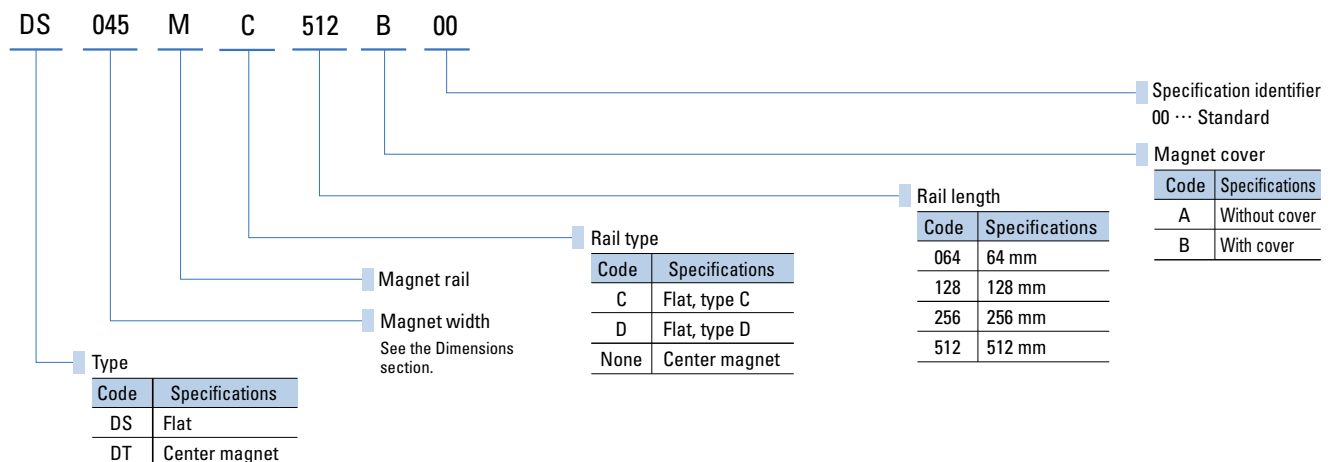

Flat type with core

[Unit in drawings: mm]

Specifications

Coil model no.	Rated thrust [N]	Maximum thrust [N]	Rated speed [m/s]	Max. speed [m/s]	Magnetic attraction force [N]	Coil mass [kg]	Compatible magnet rail model no.	Compatible servo amplifier capacity
DS025CC1AN□A□00	140	270	2.3	3.2	940	1.1	DS025MC□□□	20 A

Magnet rail model no.	Magnet rail mass [kg]	Dimensions [mm]			
		L1	L2	N1	N2
DS025MC064□00	0.1	64	32	1	4
DS025MC128□00	0.3	128	96	3	8
DS025MC256□00	0.5	256	224	7	16
DS025MC512□00	1.0	512	480	15	32

Thrust-Speed Characteristics

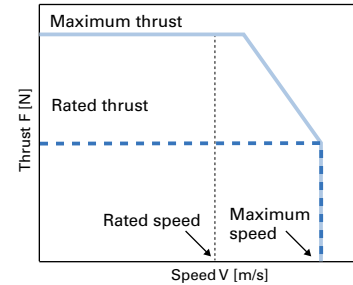

Coil dimensions

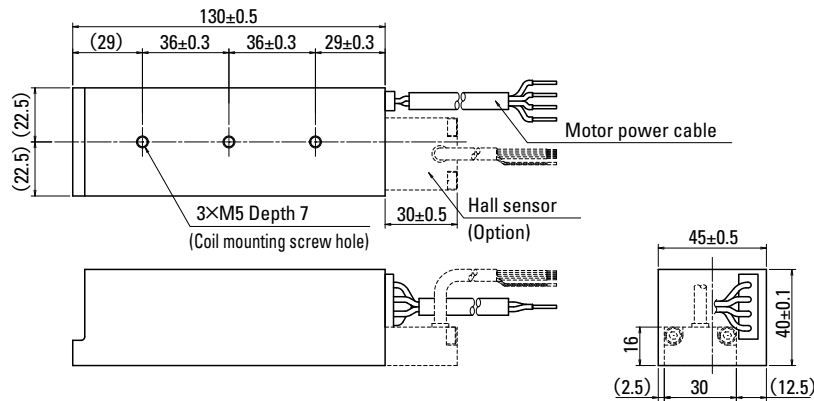

Magnet rail dimensions

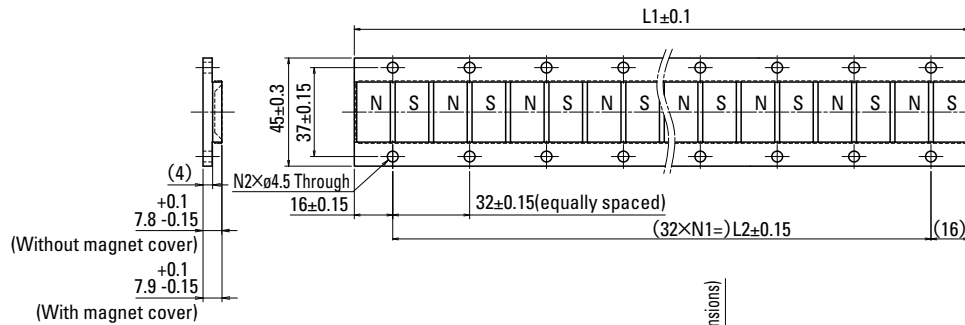
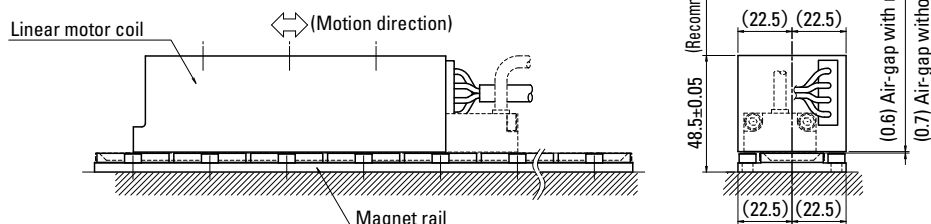

Diagram of recommended assembly example



Specifications

Coil model no.	Rated thrust [N]	Maximum thrust [N]	Rated speed [m/s]	Max. speed [m/s]	Magnetic attraction force [N]	Coil mass [kg]	Dimensions [mm]			Compatible magnet rail model no.	Compatible servo amplifier capacity
							C1	C2	C3		
DS035CC1AN□A□00	200	390	1.9	2.6	1300	1.5	55	20	12.5	DS035MC□□□□	30 A
DS045CC1AN□A□00	260	500	1.8	3.0	1700	1.8	65	30	17.5	DS045MC□□□□	30 A
DS055CC1AN□A□00	310	600	1.9	3.0	2300	2.1	75	40	22.5	DS055MC□□□□	30 A
DS065CC1AN□A□00	340	700	2.1	3.0	2700	2.5	85	50	27.5	DS065MC□□□□	50 A

Magnet rail model no.	Magnet rail mass [kg]	Dimensions [mm]														
		L1	L2	N1	N2	E1	E2	E3	E4	E5	S1	S2	S3	S4	S5	
DS035MC064□□00	0.2	64	32	1	4	55	47	4	7.8	7.9	27.5	27.5	48.5	0.6	0.7	
DS035MC128□□00	0.3	128	96	3	8	55	47	4	7.8	7.9	27.5	27.5	48.5	0.6	0.7	
DS035MC256□□00	0.7	256	224	7	16	55	47	4	7.8	7.9	27.5	27.5	48.5	0.6	0.7	
DS035MC512□□00	1.3	512	480	15	32	55	47	4	7.8	7.9	27.5	27.5	48.5	0.6	0.7	
DS045MC064□□00	0.2	64	32	1	4	62	54	4	7.8	7.9	32.5	31	48.5	0.6	0.7	
DS045MC128□□00	0.4	128	96	3	8	62	54	4	7.8	7.9	32.5	31	48.5	0.6	0.7	
DS045MC256□□00	0.8	256	224	7	16	62	54	4	7.8	7.9	32.5	31	48.5	0.6	0.7	
DS045MC512□□00	1.5	512	480	15	32	62	54	4	7.8	7.9	32.5	31	48.5	0.6	0.7	
DS055MC064□□00	0.3	64	32	1	4	75	67	5.5	9.5	9.6	37.5	37.5	50	0.4	0.5	
DS055MC128□□00	0.6	128	96	3	8	75	67	5.5	9.5	9.6	37.5	37.5	50	0.4	0.5	
DS055MC256□□00	1.2	256	224	7	16	75	67	5.5	9.5	9.6	37.5	37.5	50	0.4	0.5	
DS055MC512□□00	2.4	512	480	15	32	75	67	5.5	9.5	9.6	37.5	37.5	50	0.4	0.5	
DS065MC064□□00	0.4	64	32	1	4	85	77	5.5	9.5	9.6	42.5	42.5	50	0.4	0.5	
DS065MC128□□00	0.7	128	96	3	8	85	77	5.5	9.5	9.6	42.5	42.5	50	0.4	0.5	
DS065MC256□□00	1.4	256	224	7	16	85	77	5.5	9.5	9.6	42.5	42.5	50	0.4	0.5	
DS065MC512□□00	2.8	512	480	15	32	85	77	5.5	9.5	9.6	42.5	42.5	50	0.4	0.5	

Thrust-Speed Characteristics

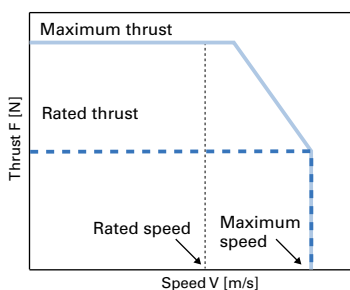

Coil dimensions

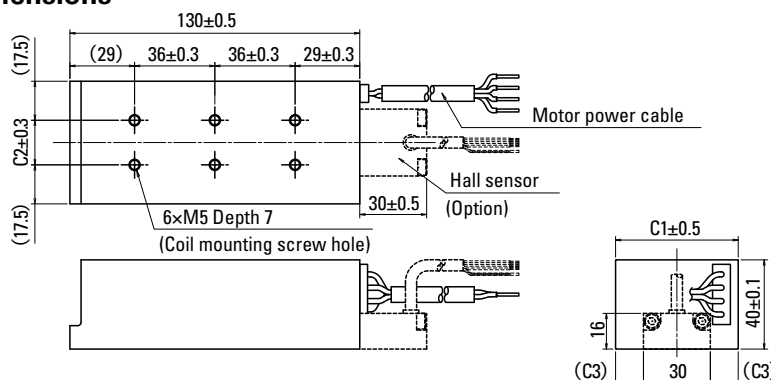

Magnet rail dimensions

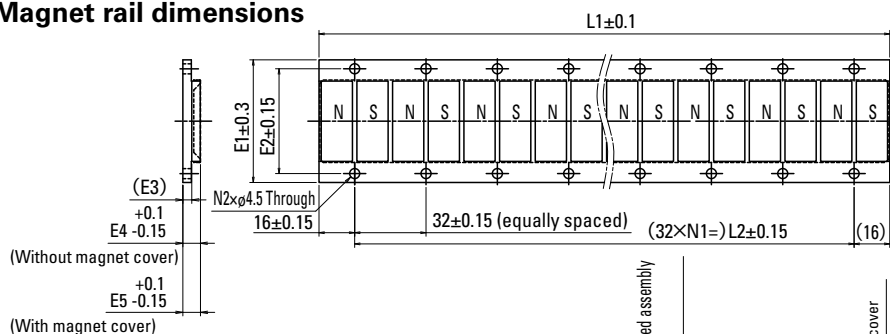
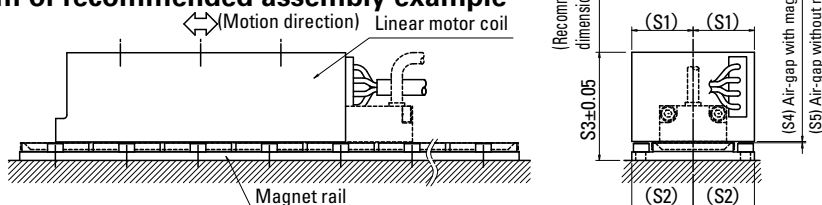

Diagram of recommended assembly example



Flat type with core

[Unit in drawings: mm]

Specifications

Coil model no.	Rated thrust [N]	Maximum thrust [N]	Rated speed [m/s]	Max. speed [m/s]	Magnetic attraction force [N]	Coil mass [kg]	Compatible magnet rail model no.	Compatible servo amplifier capacity
DS050CD1AN□A□00	340	630	2.0	3.0	2000	2.15	DS050MD□□□	30 A

Magnet rail model no.	Magnet rail mass [kg]	Dimensions [mm]			
		L1	L2	N1	N2
DS050MD064□00	0.2	64	32	1	4
DS050MD128□00	0.5	128	96	3	8
DS050MD256□00	0.9	256	224	7	16
DS050MD512□00	1.8	512	480	15	32

Thrust-Speed Characteristics

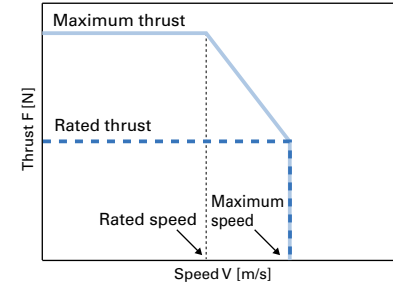

Coil dimensions

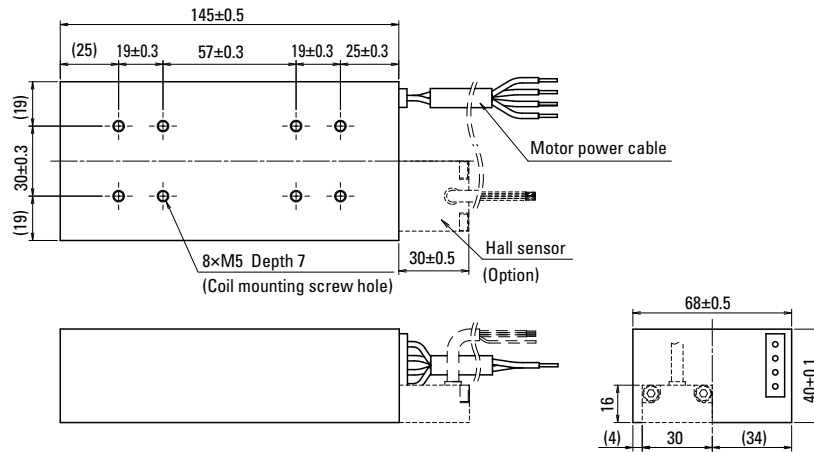

Magnet rail dimensions

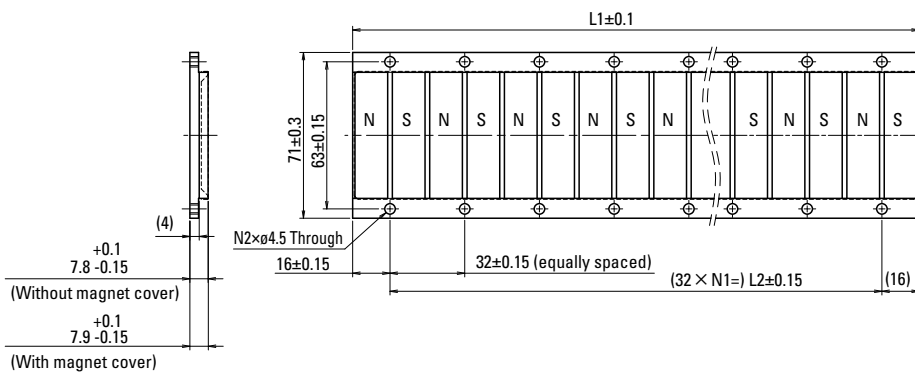
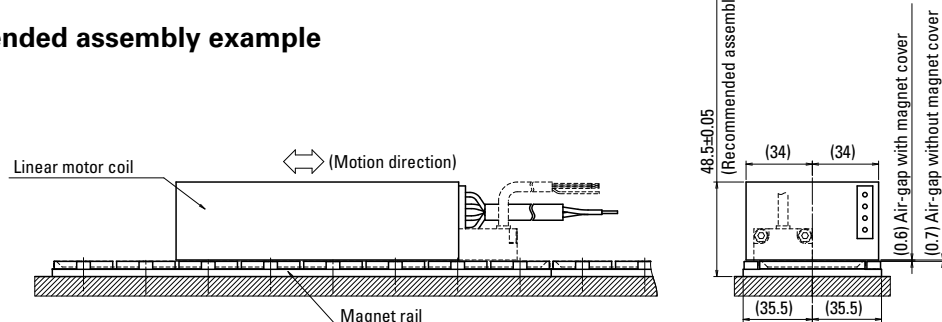

Diagram of recommended assembly example



Center magnet type with core

[Unit in drawings: mm]

Specifications

Coil model no.	Rated thrust [N]	Maximum thrust [N]	Rated speed [m/s]	Max. speed [m/s]	Magnetic attraction force [N]	Coil mass [kg]	Compatible magnet rail model no.	Compatible servo amplifier capacity
DT030CD1AN□A□00	350	650	1.9	2.5	0	2.4	DT030M□□□	30 A

Magnet rail model no.	Magnet rail mass [kg]	Dimensions [mm]				
		L1	L2	L3	N1	N2
DT030M128□□00	0.5	128	96	80	7	6
DT030M256□□00	0.9	256	224	208	15	14
DT030M512□□00	1.9	512	480	464	31	30

Thrust-Speed Characteristics

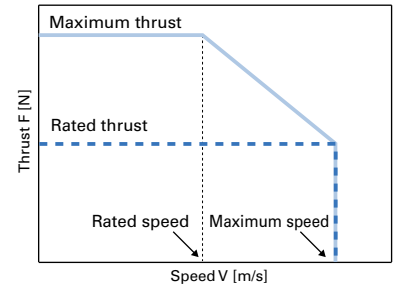

Coil dimensions

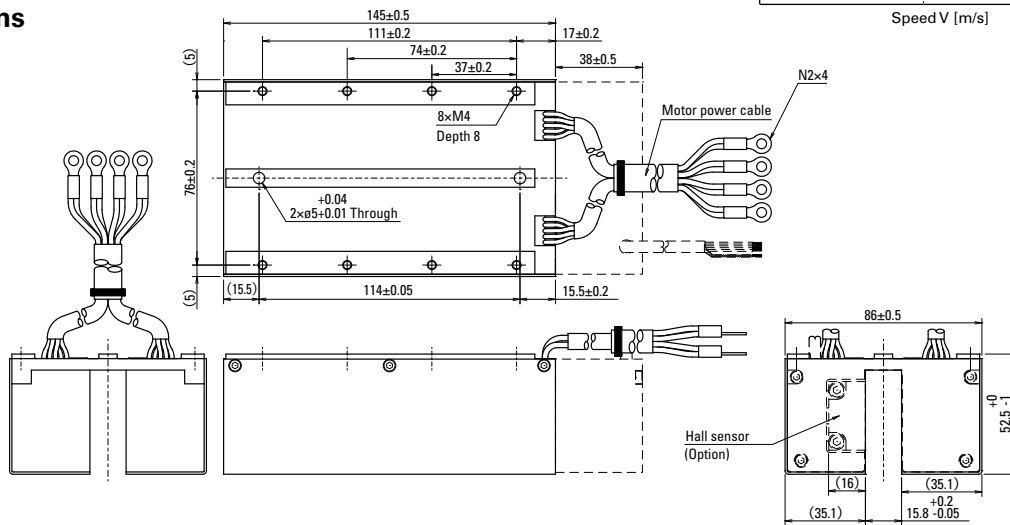

Magnet rail dimensions

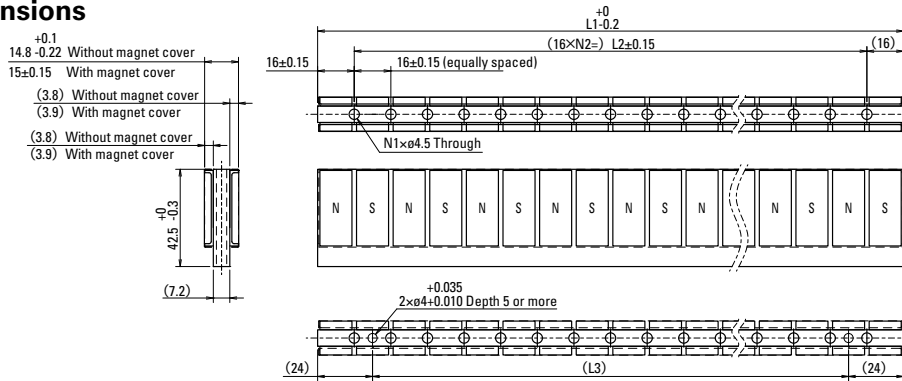
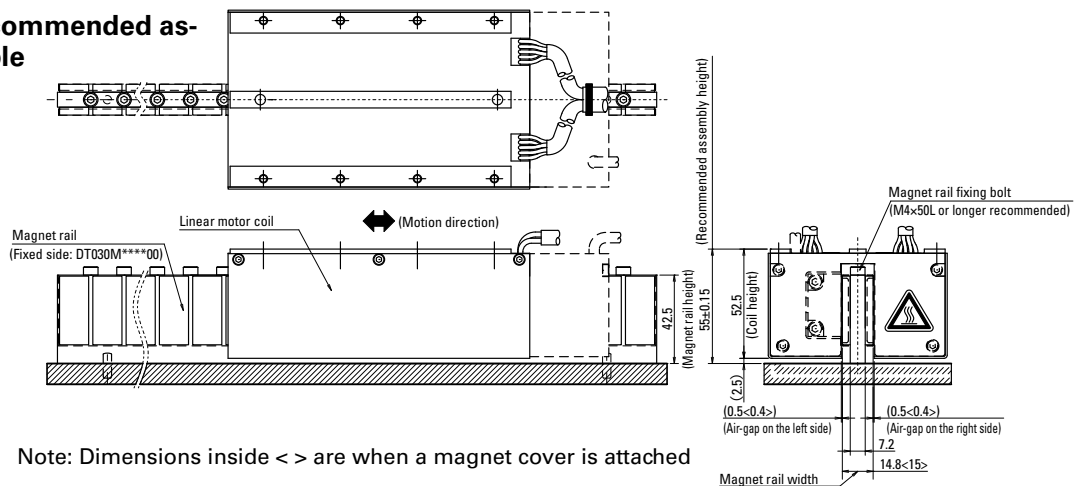

Diagram of recommended assembly example



Note: Dimensions inside < > are when a magnet cover is attached

Servo Amplifiers

Analog/Pulse input type

Amplifier capacity: 10 to 50 A



How to read model numbers

Note that not all possible combinations of field values may yield valid products. Also, some of the values listed below are for options. Refer to the Standard Model Number List section for standard models with valid model numbers.

GA D SA 01 A A 2 2

Option 2

Code	STO function	Tandem operation function	Standard/Option
0	—	—	Option
2	✓ (Without delay circuit)	✓	Standard
4	✓ (With delay circuit)	✓	Option

Motor encoder type

Rotary motor

Code	Connector X3 (Upper) For rotary motor encoders only	Connector X4 (Lower) For rotary motor encoders/ external encoders	Standard/Option
1	Absolute encoder	Absolute encoder	Option
2	Absolute encoder	Incremental encoder	Standard
A	Incremental encoder	Incremental encoder	Option

Linear motor

Code	Connector X3 (Upper) For linear motor encoders only	Connector X4 (Lower) For linear motor encoders/ hall sensors	Standard/Option
2	Absolute encoder	Incremental encoder	Standard
A	Incremental encoder	Line driver	Option

Interface

Code	Specifications
A	Analog/Pulse, sinking type general-purpose output
B	Analog/Pulse, sourcing type general-purpose output

Option 1

Code	Specifications
A	With built-in regenerative resistor & With DB resistor
L	Without built-in regenerative resistor & With DB resistor

Amplifier capacity

Code	Specifications
01	10 A
02	20 A
03	30 A
05	50 A

Input power supply voltage

Code	Specifications
SA	200 VAC
SE	100 VAC

D...Servo amplifier

GA...SANMOTION G series

System Configuration

10 to 50 A The photo shows a 30 A model.

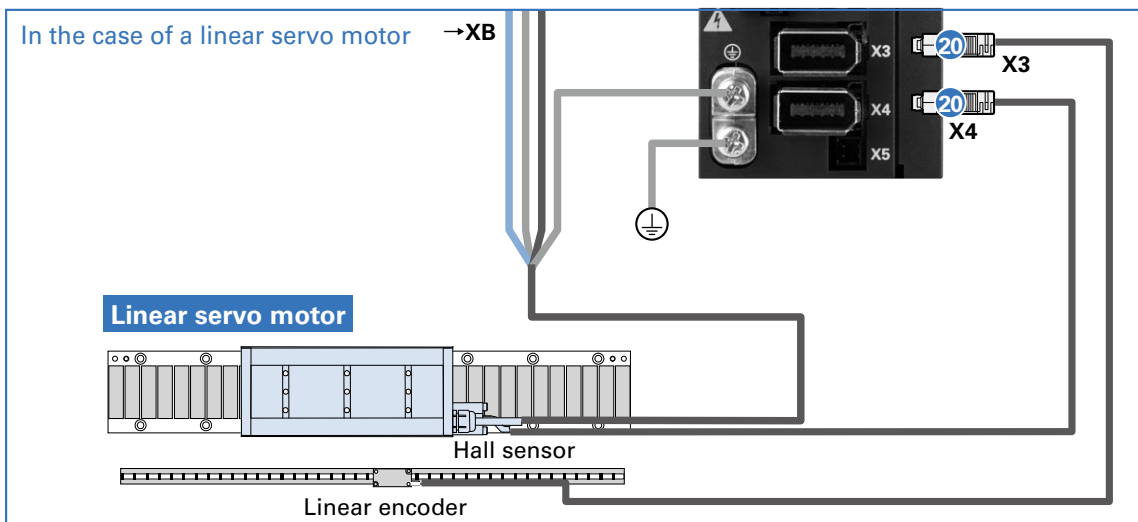
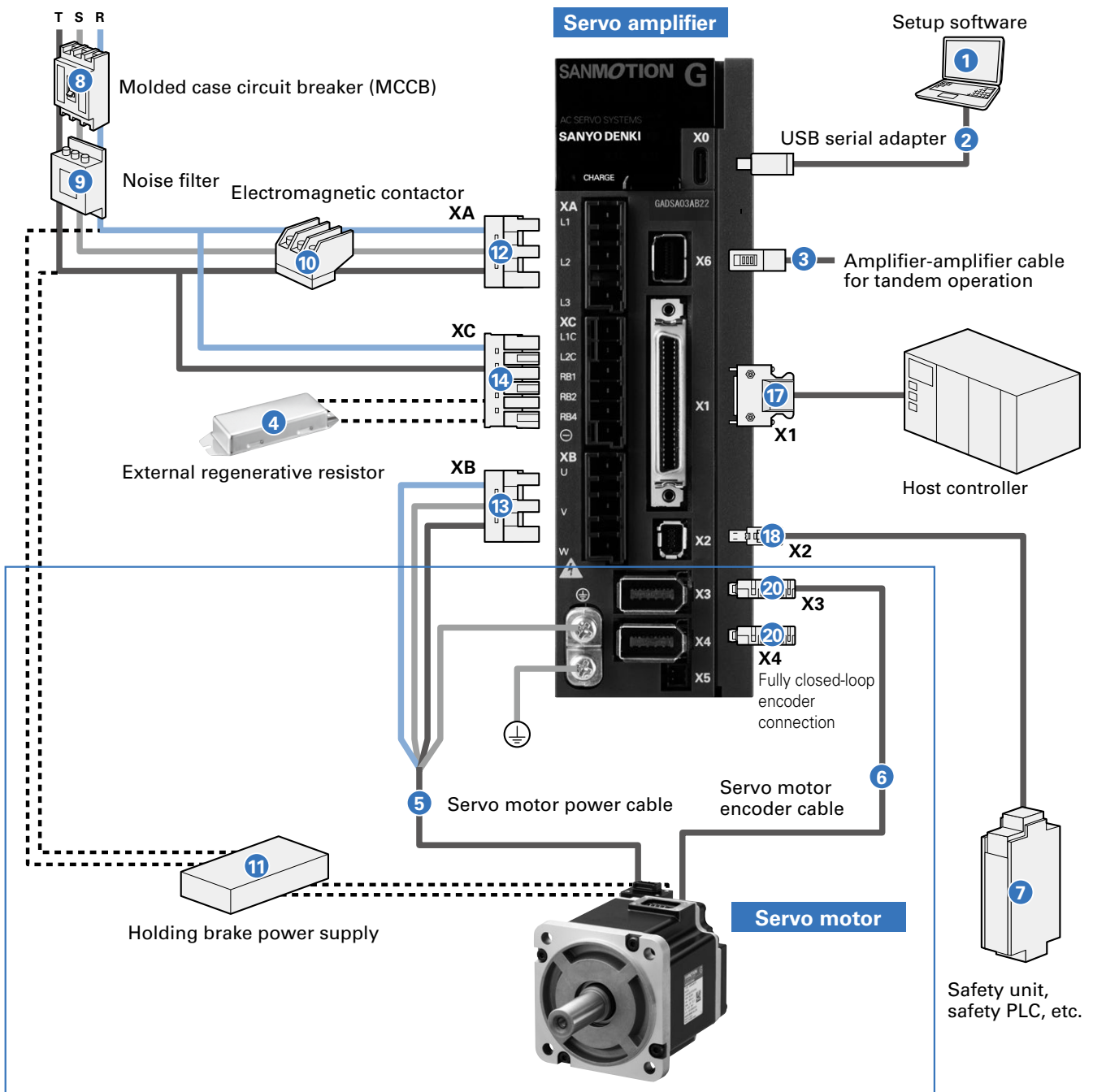

Options and Peripheral Items (10 to 50 A)

No.	Name	Model no.	Description
1	Setup software	Can be downloaded from Product Information on our website.	Parameters can be set and monitored via communication with a PC.
2	USB communication cable	AL-Y0020355-0□	PC side: Type A, amplifier side: Type C
		AL-Y0021049-0□	PC side: Type C, amplifier side: Type C
3	Amplifier-to-amplifier cable for tandem operation	AL-01134653-0□	Connects between amplifiers for tandem operation (X6 ↔ X6) Consult us if using the tandem operation function.
4	External regenerative resistor	AL-R□□□W□□B	Used when more regenerative capacity is needed, e.g., high-frequency movements
5	Servo motor power cable	p. 65, p. 66	For rotary motors only
6	Servo motor encoder cable	p. 66	
7	Safety unit, safety PLC, etc. To be provided by the customer	To be provided by the customer	Connects I/O signals from the STO function to devices such as a safety unit and safety PLC.
8	Molded case circuit breaker (MCCB)	To be provided by the customer	Used to protect power lines
9	Noise filter	To be provided by the customer	Used to prevent external noise from power lines
10	Electromagnetic contactor	To be provided by the customer	Used to switch the power on and off (prepare a protective circuit)
11	Holding brake	To be provided by the customer	Used for servo motors with holding brake

Individual connectors Amplifiers with 19X2 connector come with a short-circuit STO connector. Other connectors are not included and need to be prepared by customer.

No.	Connector code	Details	Model no.	Mfr. part no.	Manufacturer	
12	XA	Power connector	For main circuit power supply connection	AL-01111794-01	J.S.T.	
13	XB		For servo motor/linear servo motor connection	AL-01111795-01		03JFAT-SAYGDK-KT10
14	XC		For control circuit power supply / external regenerative resistor connection	AL-01111793-01		06JFAT-SAXGDK-K5.0
15	XC		For control circuit power supply / built-in regenerative resistor connection (with short-circuit jumper)	AL-AP000439-01		06JFAT-SAXGDK-K5.0 + Shorting bar
16	OT	Connector tool for XA/XB/XC	AL-00961844-01	J-FAT-OT(N)		
17	X1	GPIO connector	AL-00385594	10150-3000PE and 10350-52A0-008	3M Japan, Ltd	
18	X2	Signal connector	STO wiring connector	AL-00718252-01	Tyco Electronics Japan G.K.	
19	X2		STO short-circuit connector*	AL-00849548-02		1971153-2
20	X3, X4	For encoder connection (With linear servo motors, linear encoder / hall sensor connection)	AL-00530312-01	54599-1019	Molex Japan Co., Ltd.	

* If not wiring X2, be sure to insert a supplied short-circuit STO connector to X2.

Power connector sets

Name	Model no.	Connectors included in the set (see above, numbers in the "Individual connectors" table)				
		12 XA	13 XB	14 XC	15 XC with shorting bar	16 OT
Power connector set A (With built-in regenerative resistor)	AL-01135740-01	✓	✓	–	✓	✓
Power connector set B (With external regenerative resistor)	AL-01133414-01	✓	✓	✓	–	✓

Signal connector sets

Name	Model no.	Connectors included in the set (see above, numbers in the "Individual connectors" table)		
		17 X1	18 X2	20 X3, X4
Signal connector set A1 (STO not used)	AL-01136300-01	✓	– Use the short-circuiting connector included with the servo amplifier	✓
Signal connector set A2 (STO used)	AL-01136301-01	✓	✓	✓

Power/Signal connector set For semi closed-loop control. When using fully closed-loop control or using a hall sensor with a linear servo motor, prepare another 20 encoder connector.

Name	Built-in regenerative resistor	STO function	Model no.	Connectors included in the set (see above, numbers in the "Individual connectors" table)							
				12 XA	13 XB	14 XC	15 XC with shorting bar	16 OT	17 X1	18 X2	20 X3, X4
Power/Signal connector set A	✓	–	AL-01134646-01	✓	✓	–	✓	✓	✓	–	✓
	–	–	AL-01134645-01	✓	✓	✓	–	✓	✓	–	✓
	✓	✓	AL-01134648-01	✓	✓	–	✓	✓	✓	✓	✓
	–	✓	AL-01134647-01	✓	✓	✓	–	✓	✓	✓	✓

General Specifications



Model no.	GADS□01□□		GADS□02□□	GADS□03□□	GADS□05□□	
Capacity	10 A		20 A	30 A	50 A	
Maximum compatible motor output	200 W		400 W	1.5 kW	2.5 kW	
Continuous output current	1.2 Arms		3.1 Arms	5.2 Arms	12.0 Arms	
Peak output current	4.3 Arms		12.0 Arms	16.3 Arms	26.5 Arms	
Control function	Position/speed/torque control (switched with parameters)					
Control system	IGBT-based, sinusoidal PWM control					
Main circuit power supply	Input voltage range		3-phase: 200 to 240 VAC (+10, -15%), 50/60 Hz (±3 Hz) Single-phase: 200 to 240 VAC (+10, -15%), 50/60 Hz (±3 Hz) ⁽¹⁾ DC: 300 VDC (±20%) ⁽¹⁾ Single-phase: 100 to 120 VAC (+10, -15%), 50/60 Hz (±3 Hz) ⁽²⁾ DC: 150 VDC (±20%) ⁽²⁾			
	Input current (3-/single-phase)		1.2/2.0 Arms	2.2/3.9 Arms	6.9/7.0 Arms	11.0/11.6 Arms
	Power supply capacity		0.4 kVA	0.8 kVA	2.4 kVA	3.8 kVA
Control circuit power supply	Input voltage range		Single-phase: 200 to 240 VAC (+10, -15%), 50/60 Hz (±3 Hz) ⁽¹⁾ DC: 300 VDC (±20%) ⁽¹⁾ Single-phase: 100 to 120 VAC (+10, -15%), 50/60 Hz (±3 Hz) ⁽²⁾ DC: 150 VDC (±20%) ⁽²⁾			
	Input current		0.5 Arms		0.3 Arms	
Regenerative resistor	Built-in regenerative resistor	Resistance	25 Ω		17 Ω	
		Max. power consumption	5 W		20 W	
	Min. allowable external resistance		25 Ω		17 Ω	
Environment	Operating ambient temperature		0 to +60°C ⁽³⁾			
	Storage temperature		-20 to +65°C			
	Operating and storage humidity		95% RH max. (non-condensing)			
	Operating altitude		2000 m max. ⁽³⁾			
	Vibration resistance		6 m/s ²			
	Shock resistance		20 m/s ²			
Overvoltage category		III				
Structure	Built-in tray-type power supply					

(1) 200 VAC single-phase input and 300 VDC input are compatible only with GADSA□□ models. When using single-phase input or DC input, parameter settings will be necessary.
 (2) 100 VAC single-phase input and 150 VDC input are compatible only with GADSE□□ models. When using single-phase input or DC input, parameter settings will be necessary.
 (3) When used in environments with an ambient temperature of +55 to +60°C or an altitude of 1000 to 2000 m, motor performance undergoes derating.

Performance

Velocity control range	1:5000 (Internal velocity command)
Frequency characteristics	3500 Hz (With 400 W or lower motors in high-speed command mode)
Allowable range of load inertia	10 times the motor rotor inertia

Built-in functions

Protection functions	Output power device error (overcurrent), current detection error, STO error, cooling fan error, overload, regenerative error, magnetic pole position estimation error, continuous overspeed, overheating error, external error, servo amplifier temperature error, overvoltage, main circuit power supply undervoltage, main circuit power supply open phase, main circuit power supply voltage detection error, inrush current protection time error, control circuit power supply undervoltage, encoder error, overspeed, speed control error, speed feedback error, model-following vibration control error, excessive position deviation, positioning command error, excessive inter-axis synchronization deviation, excessive dual positioning deviation, dual positioning feedback error, inter-amplifier communication error, memory error, CPU error, parameter error, control circuit error, task process error
Digital operator	Status display, parameter setting, adjustment mode, test run, alarm log, monitoring, motor code setting
Dynamic brake circuit	Built-in
Regenerative circuit	Built-in
Analog monitor	Ch 1: Velocity monitoring (VMON) 2.0 V ±10% (at 1000 min ⁻¹), Ch 2: Torque command monitoring (TCMON) 2.0 V ±10% (at 100%)

■ General-purpose output (GPO) specifications

Sinking type

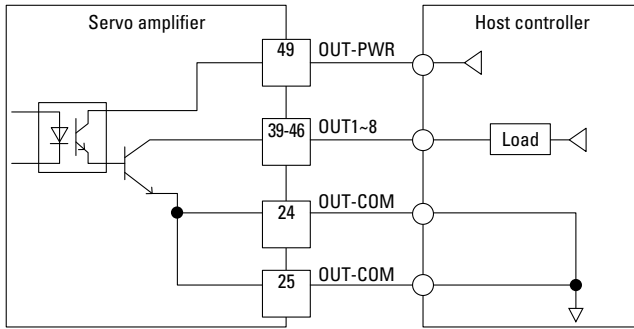

Sourcing type

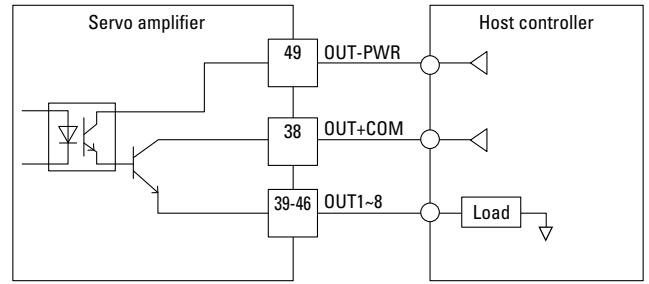

Dimensions [Unit: mm]

《10 A》

Mass : 0.80 kg

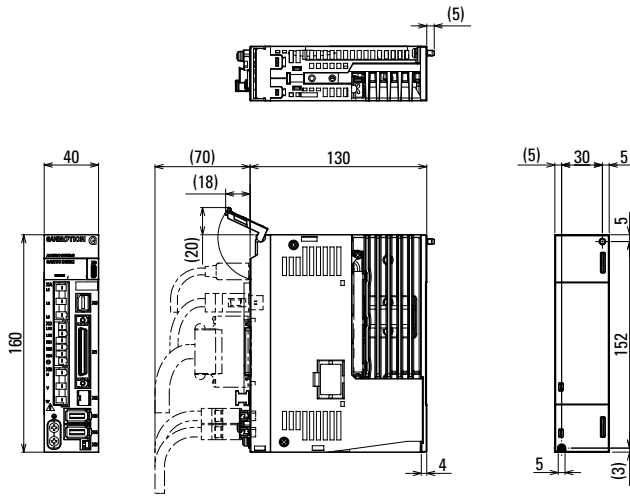

《20 A》

Mass : 0.80 kg

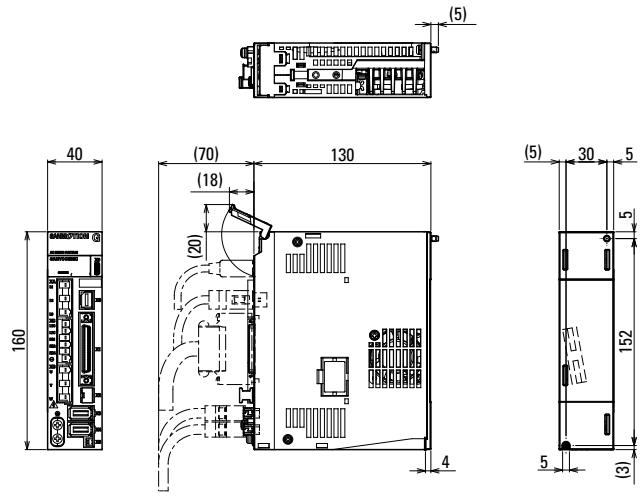

《30 A》

Mass : 0.90 kg

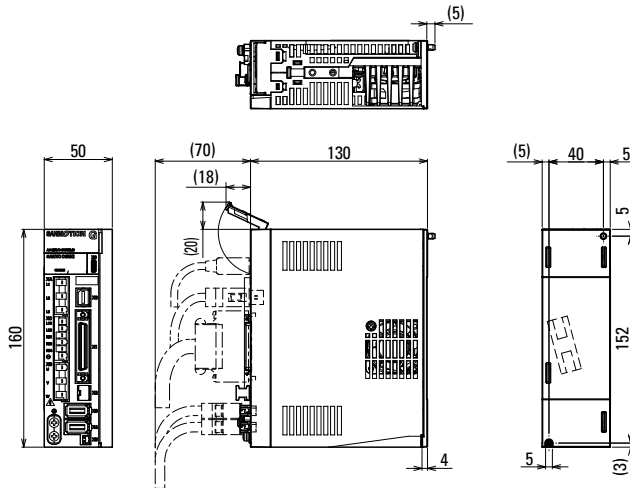

《50 A》

Mass : 1.50 kg

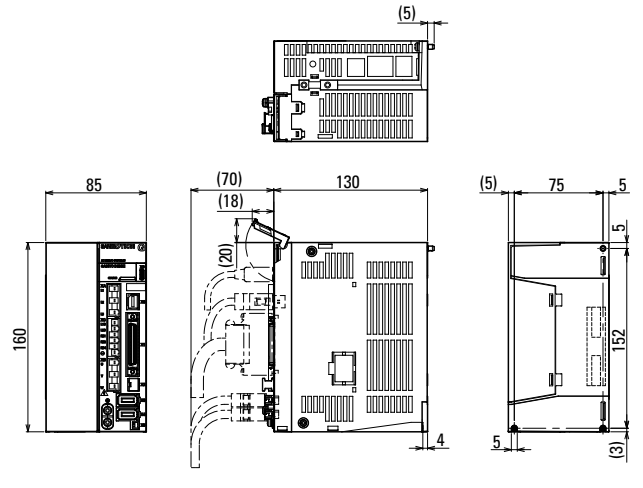

External Wiring Diagram

Sinking output

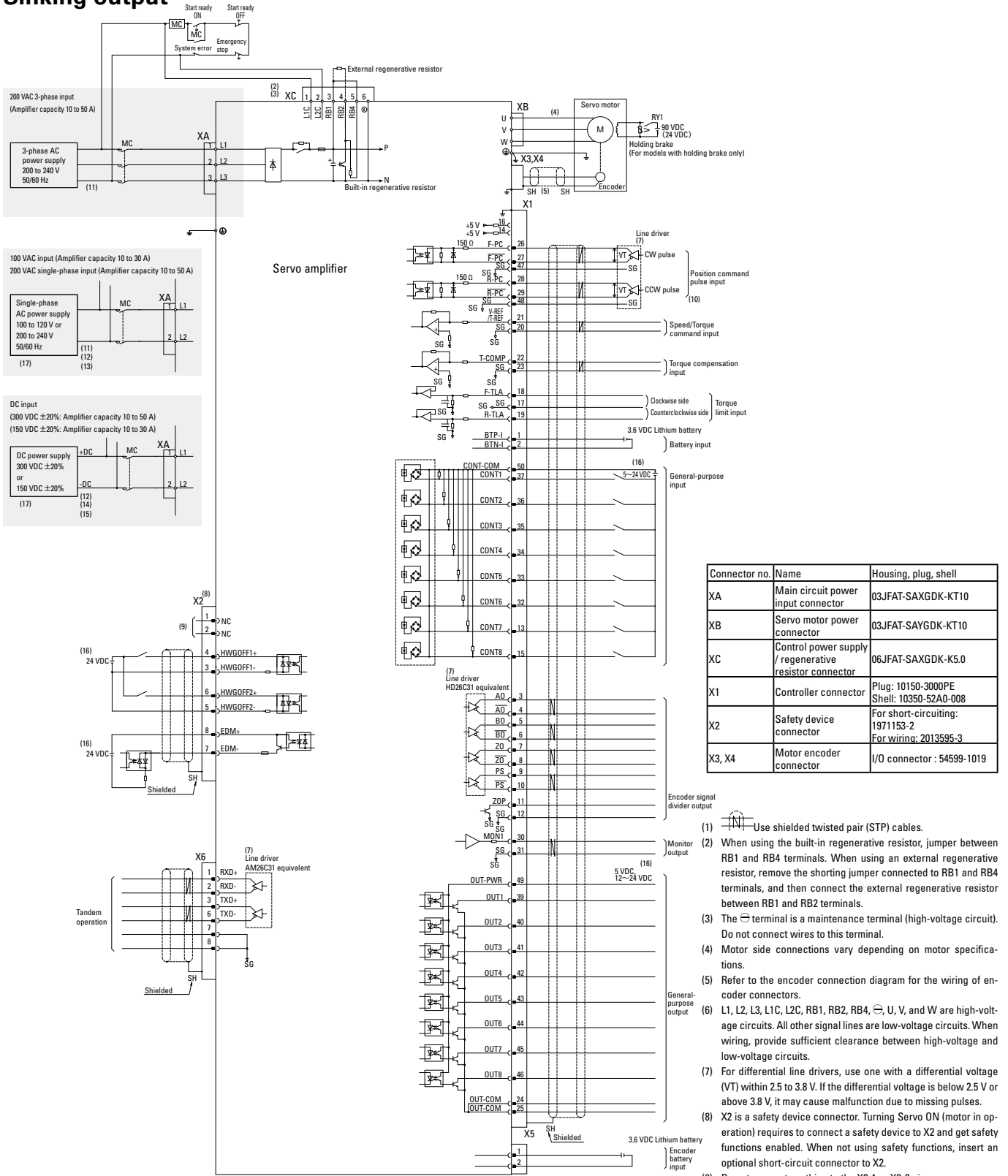

Connector no.	Name	Housing, plug, shell
XA	Main circuit power input connector	03JFAT-SAXGDK-KT10
XB	Servo motor power connector	03JFAT-SAYGDK-KT10
XC	Control power supply / regenerative resistor connector	06JFAT-SAXGDK-K5.0
X1	Controller connector	Plug: 10150-3000PE Shell: 10350-52A0-008
X2	Safety device connector	For short-circuiting: 1971153-2 For wiring: 2013595-3
X3, X4	Motor encoder connector	I/O connector : 54599-1019

- Use shielded twisted pair (STP) cables.
- When using the built-in regenerative resistor, jumper between RB1 and RB4 terminals. When using an external regenerative resistor, remove the shorting jumper connected to RB1 and RB4 terminals, and then connect the external regenerative resistor between RB1 and RB2 terminals.
- The terminal is a maintenance terminal (high-voltage circuit). Do not connect wires to this terminal.
- Motor side connections vary depending on motor specifications.
- Refer to the encoder connection diagram for the wiring of encoder connectors.
- L1, L2, L3, L1C, L2C, RB1, RB2, RB4, U, V, and W are high-voltage circuits. All other signal lines are low-voltage circuits. When wiring, provide sufficient clearance between high-voltage and low-voltage circuits.
- For differential line drivers, use one with a differential voltage (VT) within 2.5 to 3.8 V. If the differential voltage is below 2.5 V or above 3.8 V, it may cause malfunction due to missing pulses.
- X2 is a safety device connector. Turning Servo ON (motor in operation) requires to connect a safety device to X2 and get safety functions enabled. When not using safety functions, insert an optional short-circuit connector to X2.
- Do not connect anything to the X2-1 or X2-2 pins.
- When using a differential input signal, be sure to connect the signal ground (SG) between the servo amplifier and equipment.
- Use of a UL or IEC/EN compliant leakage circuit breaker is recommended.
- When using single-phase 100/200 VAC or VDC input, connect the main circuit power supply to L1 and L2, and do not use L3.
- When using a single-phase power supply, please check our User's Manual or Product Specification for accompanying limitations.
- Use of a UL or IEC/EN compliant leakage circuit breaker is recommended on the primary side of the DC power supply.
- When using a DC power supply, please check our User's Manual or Product Specification for accompanying limitations.
- An external power supply is to be prepared by the customer.
- Use an input voltage that meets the product specifications.

External Wiring Diagram

Sourcing output

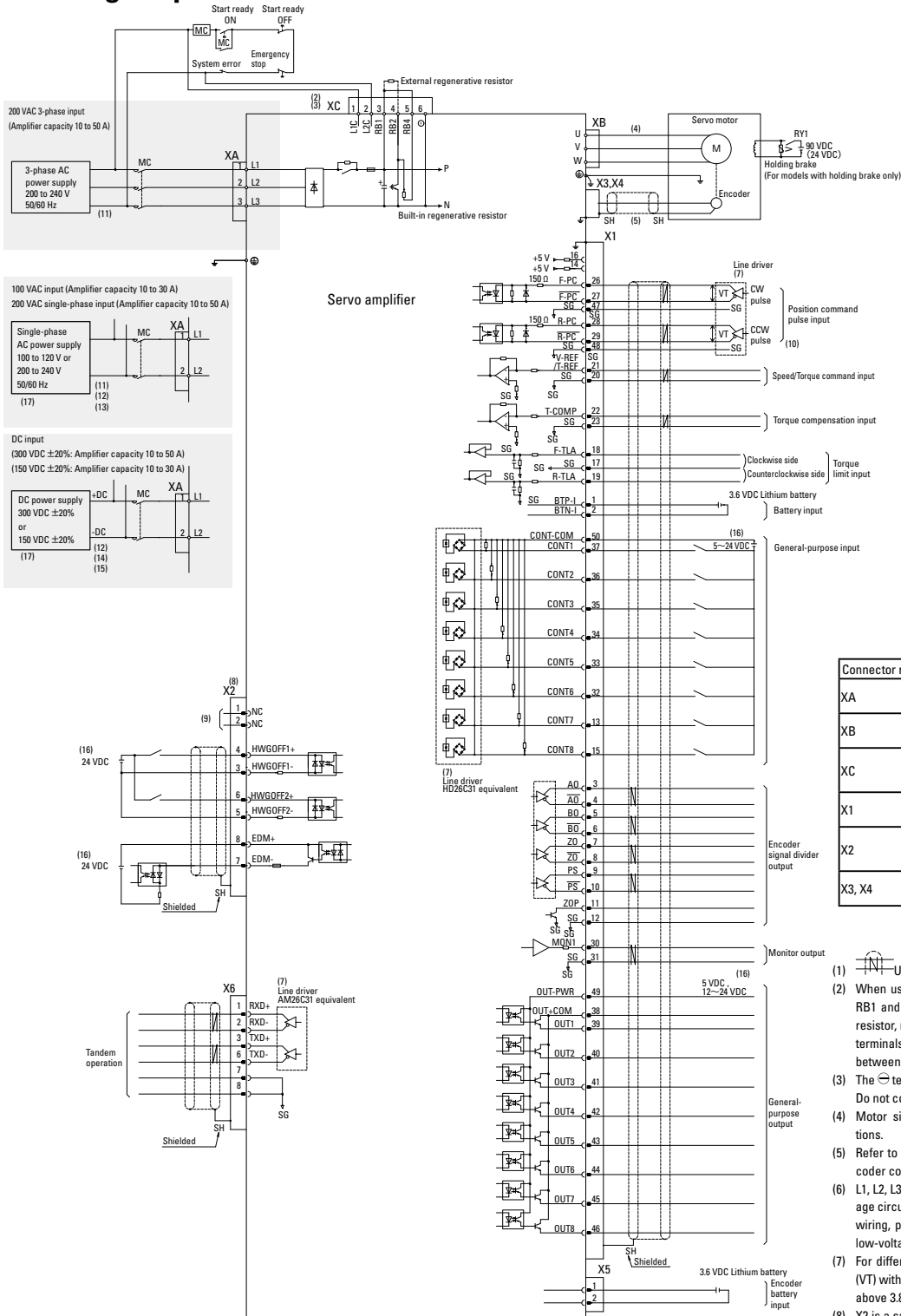

Connector no.	Name	Housing, plug, shell
XA	Main circuit power input connector	03JFAT-SAXGDK-KT10
XB	Servo motor power connector	03JFAT-SAYGDK-KT10
XC	Control power supply / regenerative resistor connector	06JFAT-SAXGDK-K5.0
X1	Controller connector	Plug: 10150-3000PE Shell: 10350-52A0-008
X2	Safety device connector	For short-circuiting: 1971153-2 For wiring: 2013595-3
X3, X4	Motor encoder connector	I/O connector: 54599-1019

- Use shielded twisted pair (STP) cables.
- When using the built-in regenerative resistor, jumper between RB1 and RB4 terminals. When using an external regenerative resistor, remove the shorting jumper connected to RB1 and RB4 terminals, and then connect the external regenerative resistor between RB1 and RB2 terminals.
- The terminal is a maintenance terminal (high-voltage circuit). Do not connect wires to this terminal.
- Motor side connections vary depending on motor specifications.
- Refer to the encoder connection diagram for the wiring of encoder connectors.
- L1, L2, L3, L1C, L2C, RB1, RB2, RB4, U, V, and W are high-voltage circuits. All other signal lines are low-voltage circuits. When wiring, provide sufficient clearance between high-voltage and low-voltage circuits.
- For differential line drivers, use one with a differential voltage (VT) within 2.5 to 3.8 V. If the differential voltage is below 2.5 V or above 3.8 V, it may cause malfunction due to missing pulses.
- X2 is a safety device connector. Turning Servo ON (motor in operation) requires to connect a safety device to X2 and get safety functions enabled. When not using safety functions, insert an optional short-circuiting connector to X2.
- Do not connect anything to the X2-1 or X2-2 pins.
- When using a differential input signal, be sure to connect the signal ground (SG) between the servo amplifier and equipment.
- Use of a UL or IEC/EN compliant leakage circuit breaker is recommended.
- When using single-phase 100/200 VAC or VDC input, connect the main circuit power supply to L1 and L2, and do not use L3.
- When using a single-phase power supply, please check our User's Manual or Product Specification for accompanying limitations.
- Use of a UL or IEC/EN compliant leakage circuit breaker is recommended on the primary side of the DC power supply.
- When using a DC power supply, please check our User's Manual or Product Specification for accompanying limitations.
- An external power supply is to be prepared by the customer.
- Use an input voltage that meets the product specifications.

Servo Amplifiers

EtherCAT interface type

Amplifier capacity: 10 to 50 A



How to read model numbers

Note that not all possible combinations of field values may yield valid products. Also, some of the values listed below are for options. Refer to the Standard Model Number List section for standard models with valid model numbers.

GA D SA 01 A H 2 4

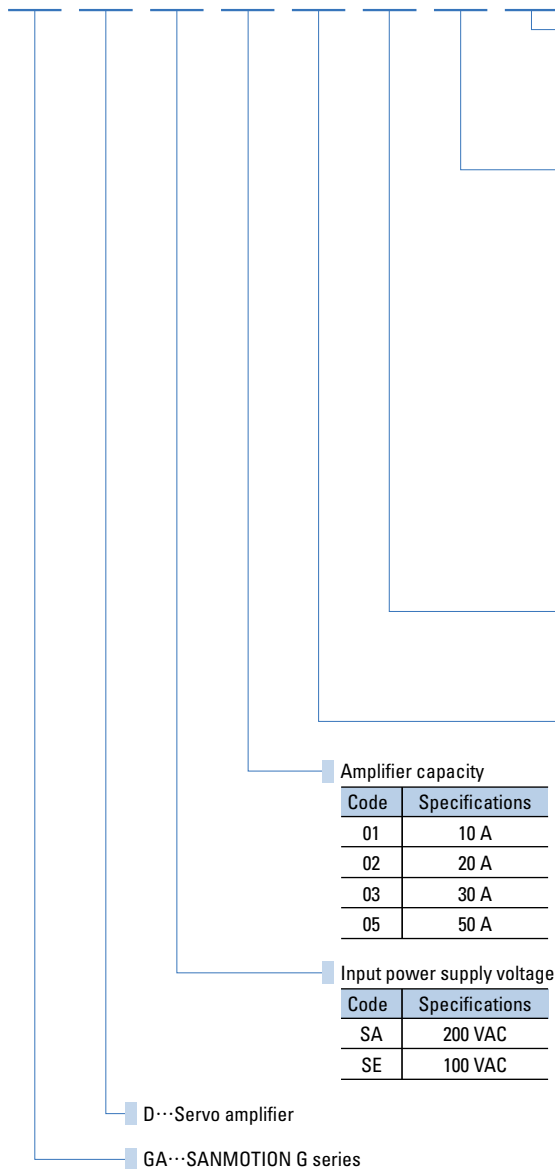

Option 2

Code	STO function	Tandem operation function	Standard/Option
2	✓ (Without delay circuit)	✓	Option
4	✓ (With delay circuit)	✓	Standard

Motor encoder type

Rotary motor

Code	Connector X3 (Upper) For rotary motor encoders only	Connector X4 (Lower) For rotary motor encoders/ external encoders	Standard/Option
1	Absolute encoder	Absolute encoder	Option
2	Absolute encoder	Incremental encoder	Standard
A	Incremental encoder	Incremental encoder	Option

Linear motor

Code	Connector X3 (Upper) For linear motor encoders only	Connector X4 (Lower) For linear motor encoders/ hall sensors	Standard/Option
2	Absolute encoder	Incremental encoder	Standard
A	Incremental encoder	Line driver	Option

Interface

Code	Specifications
H	EtherCAT

Option 1

Code	Specifications
A	With built-in regenerative resistor & With DB resistor
L	Without built-in regenerative resistor & With DB resistor

Amplifier capacity

Code	Specifications
01	10 A
02	20 A
03	30 A
05	50 A

Input power supply voltage

Code	Specifications
SA	200 VAC
SE	100 VAC

D...Servo amplifier

GA...SANMOTION G series

System Configuration

10 to 50 A The photo shows a 10 A model.

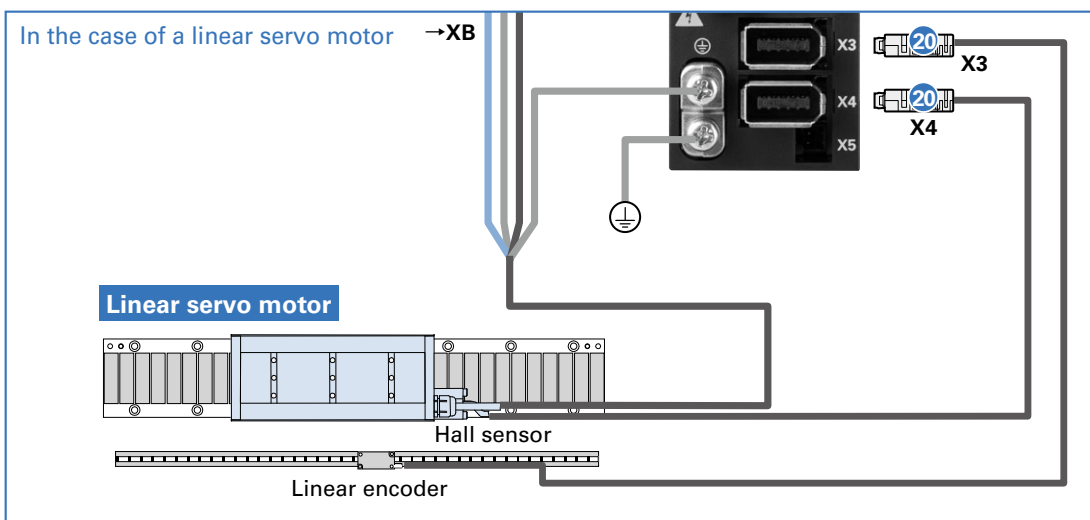
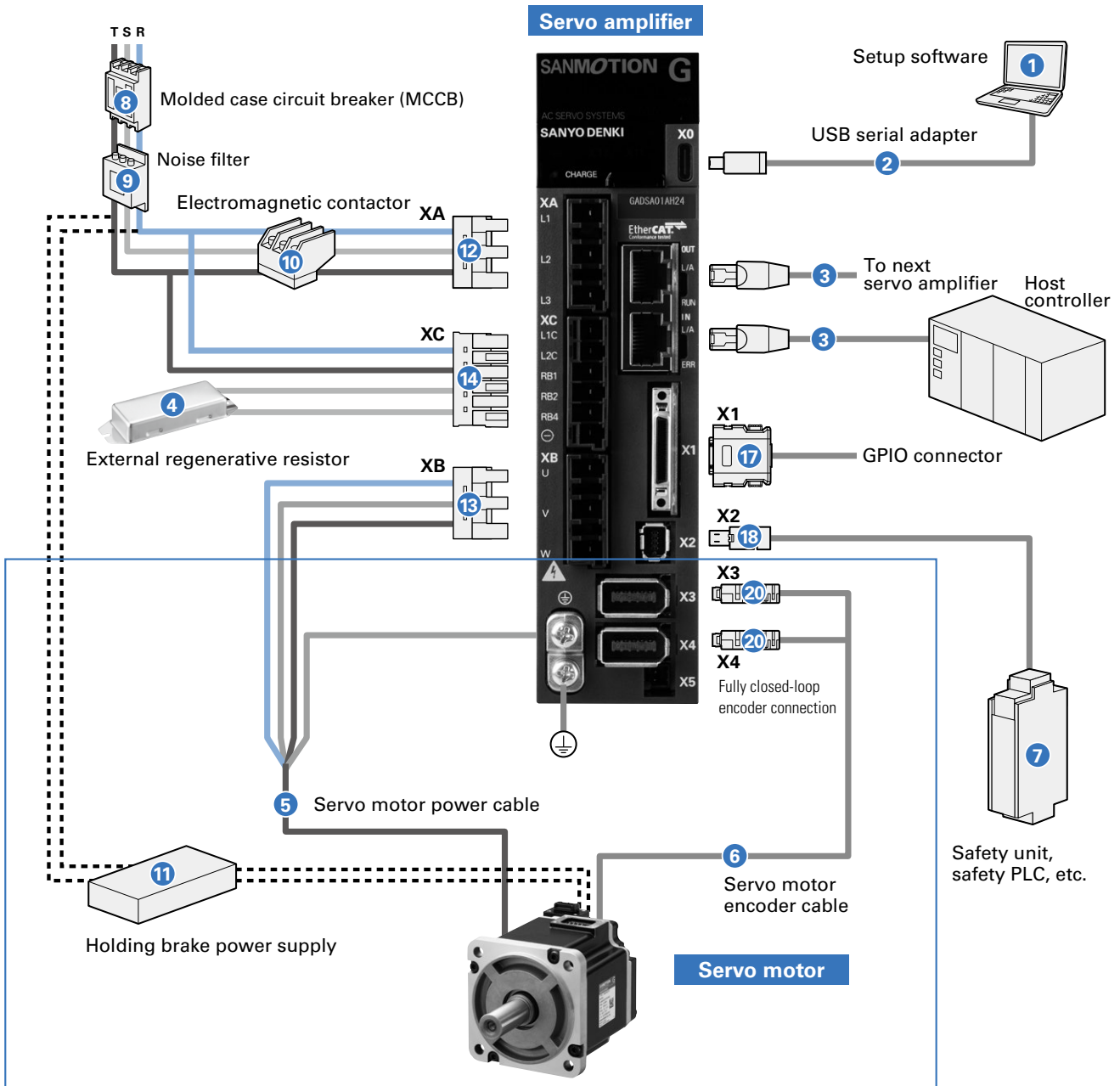

Options and Peripheral Items (10 to 50 A)

No.	Name	Model no.	Description
①	Setup software	Can be downloaded from Product Information on our website.	Parameters can be set and monitored via communication with a PC.
②	USB communication cable	AL-Y0020355-0□	PC side: Type A, amplifier side: Type C
		AL-Y0021049-0□	PC side: Type C, amplifier side: Type C
③	EtherCAT communication cable	AL-01109322-□	Communication with controller or another servo amplifier
④	External regenerative resistor	AL-R□□□W□□B	Used when more regenerative capacity is needed, e.g., high-frequency movements
⑤	Servo motor power cable	p. 65, p. 66	For rotary motors only
⑥	Servo motor encoder cable	p. 66	
⑦	Safety unit, safety PLC, etc.	To be provided by the customer	Connects I/O signals from the STO function to devices such as a safety unit and safety PLC.
⑧	Molded case circuit breaker (MCCB)	To be provided by the customer	Used to protect power lines
⑨	Noise filter	To be provided by the customer	Used to prevent external noise from power lines
⑩	Electromagnetic contactor	To be provided by the customer	Used to switch the power on and off (prepare a protective circuit)
⑪	Holding brake	To be provided by the customer	Used for servo motors with holding brake

Individual connectors Only a ⑮ short-circuit STO connector is included with the servo amplifier. Other connectors are not included and need to be prepared by customer.

No.	Connector code	Details	Model no.	Mfr. part no.	Manufacturer	
⑫	XA	Power connector	For main circuit power supply connection	AL-01111794-01	03JFAT-SAXGDK-KT10	
⑬	XB		For servo motor/linear servo motor connection	AL-01111795-01	03JFAT-SAYGDK-KT10	
⑭	XC		For control circuit power supply / external regenerative resistor connection	AL-01111793-01	06JFAT-SAXGDK-K5.0	
⑮	XC		For control circuit power supply / built-in regenerative resistor connection (with short-circuit jumper)	AL-AP000439-01	06JFAT-SAXGDK-K5.0 + Shorting bar	
⑯	OT	Connector tool for XA/XB/XC	AL-00961844-01	J-FAT-OT(N)		
⑰	X1	GPIO connector		AL-01131482-01	DH-27-CT1B, DH40-27S, DH-27-CMB(7.3)	Hirose Electric Co., Ltd.
⑱	X2	Signal connector	STO wiring connector	AL-00718252-01	2013595-3	Tyco Electronics Japan G.K.
⑲	X2		STO short-circuit connector*	AL-00849548-02	1971153-2	
⑳	X3, X4		For encoder connection (With linear servo motors, linear encoder / hall sensor connection)	AL-00530312-01	54599-1019	Molex Japan Co., Ltd.

* If not wiring X2, be sure to insert a supplied short-circuit STO connector to X2.

Power connector sets

Name	Model no.	Connectors included in the set (see above, numbers in the "Individual connectors" table)				
		⑫ XA	⑬ XB	⑭ XC	⑮ XC with shorting bar	⑯ OT
Power connector set A (With built-in regenerative resistor)	AL-01135740-01	✓	✓	–	✓	✓
Power connector set B (With external regenerative resistor)	AL-01133414-01	✓	✓	✓	–	✓

Signal connector sets

Name	Model no.	Connectors included in the set (see above, numbers in the "Individual connectors" table)		
		⑰ X1	⑱ X2	⑳ X3, X4
Signal connector set B1 (STO not used)	AL-01136298-01	✓	– Use the short-circuiting connector included with the servo amplifier	✓
Signal connector set B2 (STO used)	AL-01136299-01	✓	✓	✓

Power/Signal connector set For semi closed-loop control. When using fully closed-loop control or using a hall sensor with a linear servo motor, prepare another ⑳ encoder connector.

Name	Built-in regenerative resistor	STO function	Model no.	Connectors included in the set (see above, numbers in the "Individual connectors" table)							
				⑫ XA	⑬ XB	⑭ XC	⑮ XC with shorting bar	⑯ OT	⑰ X1	⑱ X2	⑳ X3, X4
Power/Signal connector set B	✓	–	AL-01100889-01	✓	✓	–	✓	✓	✓	–	✓
	–	–	AL-01100888-01	✓	✓	✓	–	✓	✓	–	✓
	✓	✓	AL-01100925-01	✓	✓	–	✓	✓	✓	✓	✓
	–	✓	AL-01100893-01	✓	✓	✓	–	✓	✓	✓	✓

General Specifications

Model no.	GADS□01□□		GADS□02□□		GADS□03□□		GADS□05□□			
Capacity	10 A		20 A		30 A		50 A			
Maximum compatible motor output	200 W		400 W		1.5 kW		2.5 kW			
Continuous output current	1.2 Arms		3.1 Arms		5.2 Arms		12.0 Arms			
Peak output current	4.3 Arms		12.0 Arms		16.3 Arms		26.5 Arms			
Control function	Position/speed/torque control (switched with parameters)									
Control system	IGBT-based, sinusoidal PWM control									
Main circuit power supply	Input voltage range		3-phase: 200 to 240 VAC (+10, -15%), 50/60 Hz (±3 Hz) Single-phase: 200 to 240 VAC (+10, -15%), 50/60 Hz (±3 Hz) ⁽¹⁾ DC: 300 VDC (±20%) ⁽¹⁾ Single-phase: 100 to 120 VAC (+10, -15%), 50/60 Hz (±3 Hz) ⁽²⁾ DC: 150 VDC (±20%) ⁽²⁾							
	Input current (3-/single-phase)		1.2/2.0 Arms		2.2/3.9 Arms		6.9/7.0 Arms		11.0/11.6 Arms	
	Power supply capacity		0.4 kVA		0.8 kVA		2.4 kVA		3.8 kVA	
Control circuit power supply	Input voltage range		Single-phase: 200 to 240 VAC (+10, -15%), 50/60 Hz (±3 Hz) ⁽¹⁾ DC: 300 VDC (±20%) ⁽¹⁾ Single-phase: 100 to 120 VAC (+10, -15%), 50/60 Hz (±3 Hz) ⁽²⁾ DC: 150 VDC (±20%) ⁽²⁾							
	Input current		0.5 Arms				0.3 Arms			
Regenerative resistor	Built-in regenerative resistor	Resistance	25 Ω				17 Ω			
		Max. power consumption	5 W				20 W			
	Min. allowable external resistance		25 Ω				17 Ω			
Environment	Operating ambient temperature		0 to +60°C ⁽³⁾							
	Storage temperature		-20 to +65°C							
	Operating and storage humidity		95% RH max. (non-condensing)							
	Operating altitude		2000 m max. ⁽³⁾							
	Vibration resistance		6 m/s ²							
	Shock resistance		20 m/s ²							
Overvoltage category		III								
Structure	Built-in tray-type power supply									

(1) 200 VAC single-phase input and 300 VDC input are compatible only with GADSA□□ models. When using single-phase input or DC input, parameter settings will be necessary.
 (2) 100 VAC single-phase input and 150 VDC input are compatible only with GADSE□□ models. When using single-phase input or DC input, parameter settings will be necessary.
 (3) When used in environments with an ambient temperature of +55 to +60°C or an altitude of 1000 to 2000 m, motor performance undergoes derating.

Performance

Velocity control range	1:5000 (Internal velocity command)
Frequency characteristics	3500 Hz (With 400 W or lower motors in high-speed command mode)
Allowable range of load inertia	10 times the motor rotor inertia

Built-in functions

Protection functions	Output power device error (overcurrent), current detection error, STO error, cooling fan error, overload, regenerative error, magnetic pole position estimation error, continuous overspeed, overheating error, external error, servo amplifier temperature error, overvoltage, main circuit power supply undervoltage, main circuit power supply open phase, main circuit power supply voltage detection error, inrush current protection time error, control circuit power supply undervoltage, encoder error, overspeed, speed control error, speed feedback error, model-following vibration control error, excessive position deviation, positioning command error, excessive inter-axis synchronization deviation, excessive dual positioning deviation, dual positioning feedback error, inter-amplifier communication error, memory error, CPU error, parameter error, control circuit error, task process error
Digital operator	Status display, test run, alarm log, monitoring
Dynamic brake circuit	Built-in
Regenerative circuit	Built-in
Monitoring	Ch 1: Velocity monitoring (VMON) 2.0 V ±10% (at 1000 min ⁻¹), Ch 2: Torque command monitoring (TCMON) 2.0 V ±10% (at 100%)

Dimensions [Unit: mm]

《10 A》

Mass : 0.80 kg

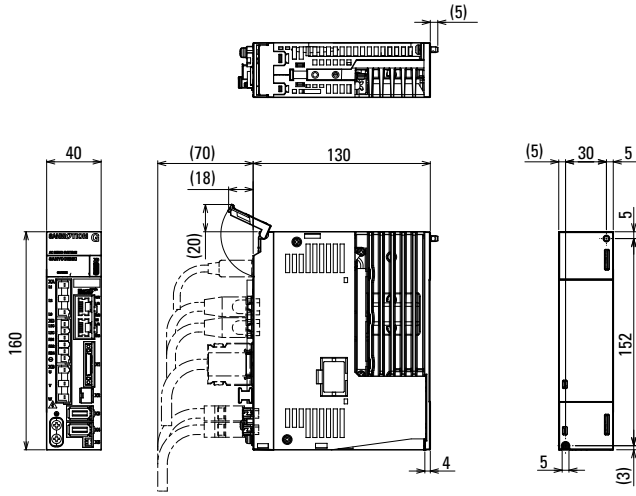

《20 A》

Mass : 0.80 kg

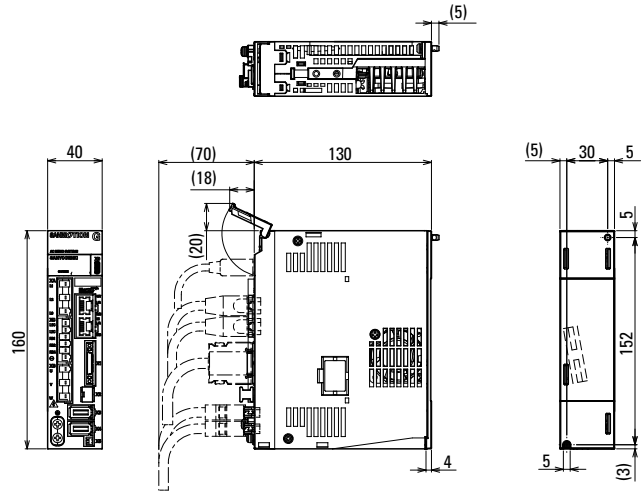

《30 A》

Mass : 0.90 kg

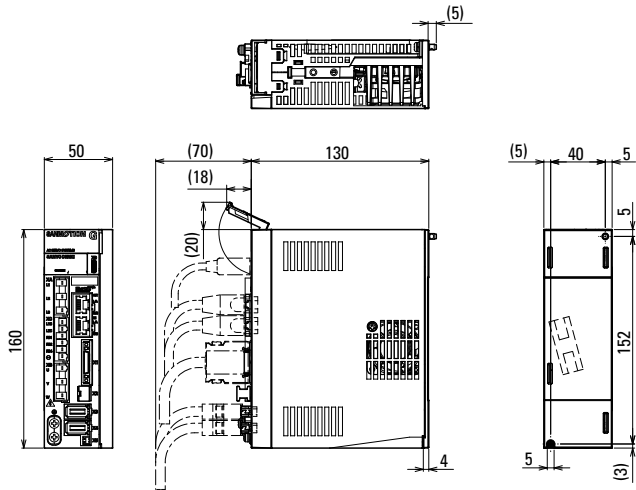

《50 A》

Mass : 1.50 kg

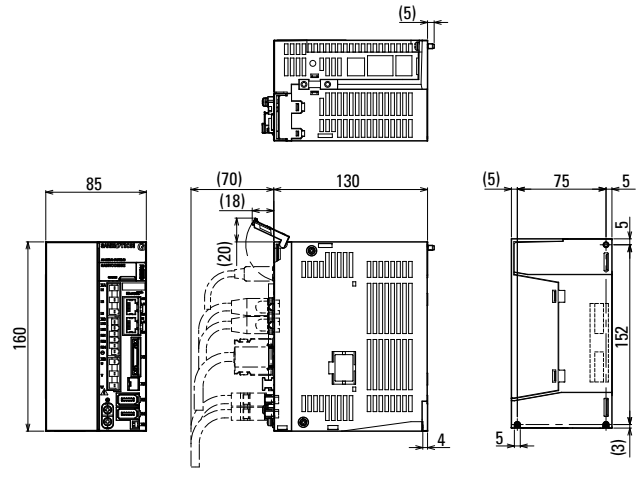

External Wiring Diagram

EtherCAT

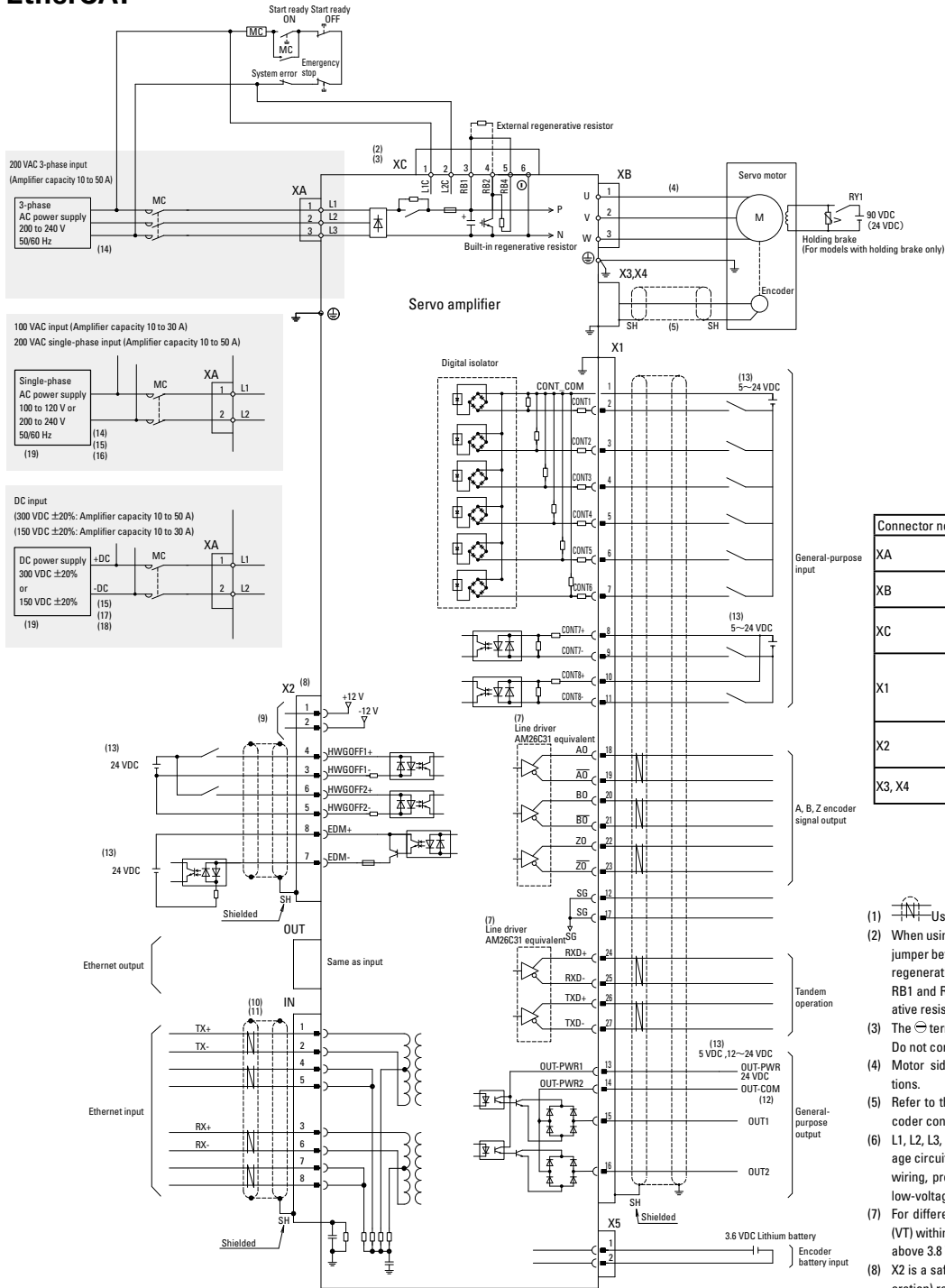

Connector no.	Name	Housing, plug, shell
XA	Main circuit power input connector	03JFAT-SAXGDK-KT10
XB	Servo motor power connector	03JFAT-SAYGDK-KT10
XC	Control power supply / regenerative resistor connector	06JFAT-SAXGDK-K5.0
X1	Controller connector	Plug: DH40-27S Cover: DH-27-CT1B Clamp: DH-27-CMB(7.3)
X2	Safety device connector	For short-circuiting: 1971153-2 For wiring: 2013595-3
X3, X4	Motor encoder connector	I/O connector: 54599-1019

- Use shielded twisted pair (STP) cables.
- When using the built-in regenerative resistor, connect a shorting jumper between RB1 and RB4 terminals. When using an external regenerative resistor, remove the shorting jumper connected to RB1 and RB4 terminals, and then connect the external regenerative resistor between RB1 and RB2 terminals.
- The terminal is a maintenance terminal (high-voltage circuit). Do not connect wires to this terminal.
- Motor side connections vary depending on motor specifications.
- Refer to the encoder connection diagram for the wiring of encoder connectors.
- L1, L2, L3, L1C, L2C, RB1, RB2, RB4, U, V, and W are high-voltage circuits. All other signal lines are low-voltage circuits. When wiring, provide sufficient clearance between high-voltage and low-voltage circuits.
- For differential line drivers, use one with a differential voltage (VT) within 2.5 to 3.8 V. If the differential voltage is below 2.5 V or above 3.8 V, it may cause malfunction due to missing pulses.
- X2 is a safety device connector. Turning Servo ON (motor in operation) requires to connect a safety device to X2 and get safety functions enabled. When not using safety functions, be sure to insert the short-circuiting connector to X2.
- Do not connect anything to the X2-1 or X2-2 pins.
- Use a category 5e (TIA standards) or better shielded twisted pair cable (STP).
- Pins 4-5 and 7-8 of the EtherCAT IN/OUT connectors are shorted inside the amplifier. Pins 4-5 and 7-8 are connected with 75 Ω resistors as shown on the diagram. It is also connected to the pulse transformer midpoint with a 75 Ω resistor.
- For sourcing type output, connect pin X1-14 to an external power supply; for sinking type output, connect pin X1-14 to GND.
- An external power supply is to be prepared by the customer.
- Use of a UL or IEC/EN compliant leakage circuit breaker is recommended.
- When using single-phase 100/200 VAC or VDC input, connect the main circuit power supply to L1 and L2, and do not use L3.
- When using a single-phase power supply, please check our User's Manual or Product Specification for accompanying limitations.
- Use of a UL or IEC/EN compliant leakage circuit breaker is recommended on the primary side of the DC power supply.
- When using a DC power supply, please check our User's Manual or Product Specification for accompanying limitations.
- Use an input voltage that meets the product specifications.

Options

Setup Software	p. 64
Cables.....	p. 65
AC Reactors	p. 67
Analog Monitors	p. 67
External Regenerative Resistors	p. 68
Front Mounting Brackets	p. 69

Setup Software

This software allows you to set servo system parameters from a PC. It also allows you to easily start up and run tests for the servo system. The software can be downloaded from Product Information on our website. <https://www.sanyodenki.com/>

■ Setup software name

SANMOTION MOTOR SETUP SOFTWARE

■ Main functions

Parameter settings (by group, by function)

Diagnosis (alarm indicator, warning indicator, alarm cancellation)

Test run execution (speed jog, positioning operation, motor home position search, serial encoder clearance)

Servo tuning (notch filter tuning, FF vibration control frequency tuning)

Various measurement functions (operating waveform display, machinery frequency response measurement)

Use a USB communication cable to connect the USB port on the PC and the servo amplifier.

■ Supported operating systems

Windows 10/11

See our website for details on supported OS versions.

New features of SANMOTION G series

GPIO monitoring

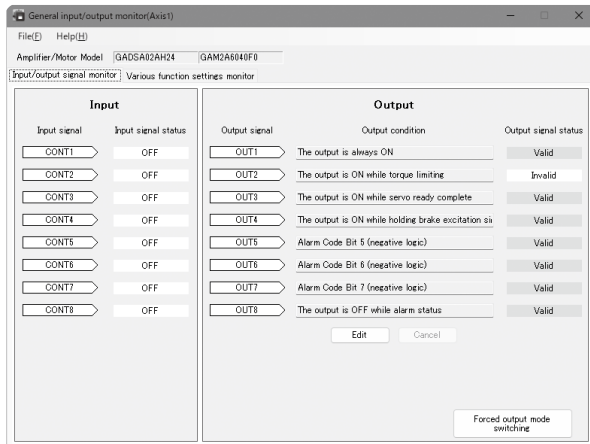

Graphically displays general-purpose I/O signal status

System analysis (high-precision mode)

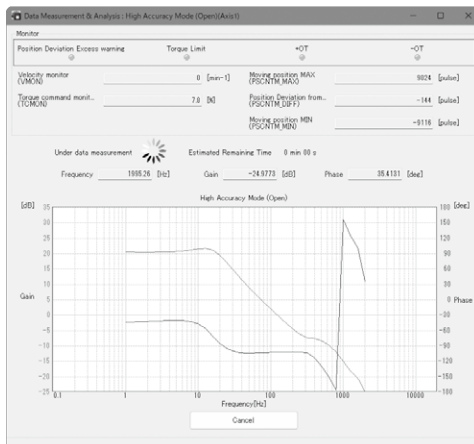

A function to measure the frequency response more precisely than the system analysis of the SANMOTION R 3E Model has been added.

Advanced tuning

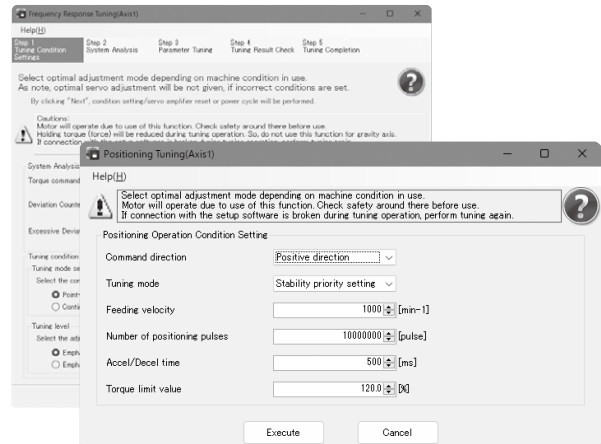

By setting the operating conditions of the machine, the frequency response characteristics and positioning settling characteristics are measured and automatically adjusted to the optimum control parameters.

Motor parameter downloader

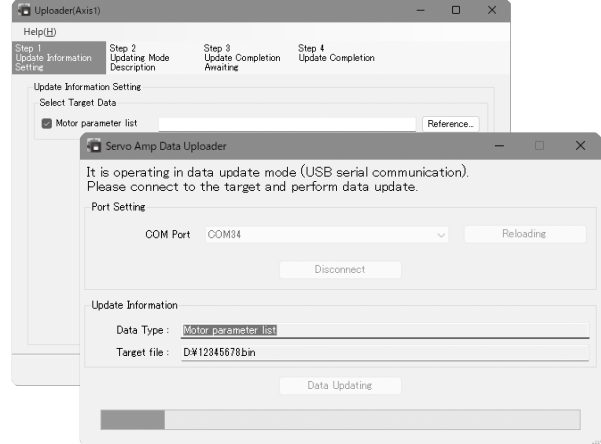

Newly added motors can be easily added with the setup software without updating the amplifier firmware.

Cables [Unit in drawings: mm]

■ USB communication cable for setup software

Communication cable with computers for setup software use.

PC side: Type A, amplifier side: Type C

Cable length: L [m]	Model no.
1.0	AL-Y0020355-01
2.0	AL-Y0020355-02

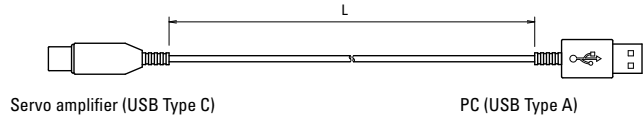

PC side: Type C, amplifier side: Type C

Cable length: L [m]	Model no.
1.0	AL-Y0021049-01
2.0	AL-Y0021049-02

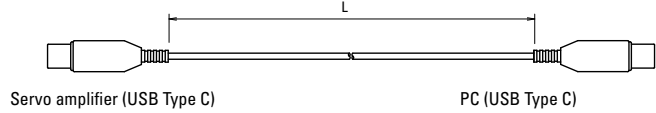

■ Amplifier-amplifier cable for tandem operation

Dedicated for analog/pulse input type

Connects between servo amplifiers for tandem operation. (X6↔X6)

Cable length: L [m]	Model no.
0.2	AL-01134653-01
3.0	AL-01134653-02

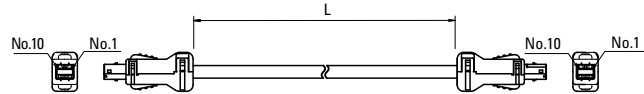

■ EtherCAT communication cable

Dedicated for EtherCAT interface type

For communication with a controller or another servo amplifier.

Cable length: L [m]	Model no.	Remarks
0.5	AL-01109322-R50	Plug: RJ-45 (TM21P-88P), on both ends
1.0	AL-01109322-01	
3.0	AL-01109322-03	Boot color: black
5.0	AL-01109322-05	Cable: 20276 ESVP AWG#24X4P, CAT5e
10.0	AL-01109322-10	

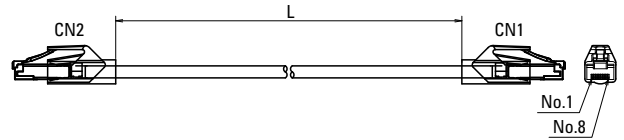

■ Servo motor power cable

The power supply for the holding brake needs to be provided by the customer.

Front and rear cable exits are directed to the output shaft direction and the opposite direction, respectively.

40 mm sq.

Cable exit direction	L [m]	Model no.
Front	1	GSSF0100S
Rear	1	GSSR0100S
Front	3	GSSF0300S
Rear	3	GSSR0300S
Front	5	GSSF0500S
Rear	5	GSSR0500S
(A) Power	22 AWG	
(B) Brake	24 AWG	
(C) Ground	22 AWG	
(D) Cable diameter	ø5.4	

Connection	Lead wire color	Motor signal name	Connector pin no.
	Red	U	1
	White	V	2
	Black	W	3
	Green/Yellow	Ground	4
	Yellow	Brake	5
	Yellow	Brake	6

60 to 86 mm sq.

Cable exit direction	L [m]	Model no.
Front	1	GMSF0100S
Rear	1	GMSR0100S
Front	3	GMSF0300S
Rear	3	GMSR0300S
Front	5	GMSF0500S
Rear	5	GMSR0500S
(A) Power	19 AWG	
(B) Brake	23 AWG	
(C) Ground	19 AWG	
(D) Cable diameter	ø6.6	

Connection	Lead wire color	Motor signal name	Connector pin no.
	Red	U	1
	White	V	2
	Black	W	3
	Green/Yellow	Ground	4
	Yellow	Brake	5
	Yellow	Brake	6

Front cable exit

Rear cable exit

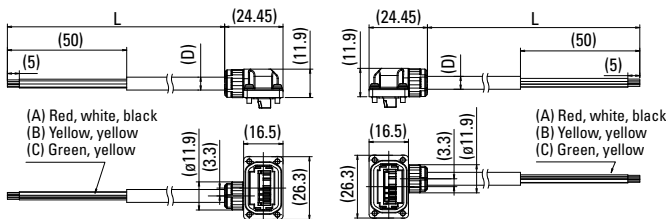

Front cable exit

Rear cable exit

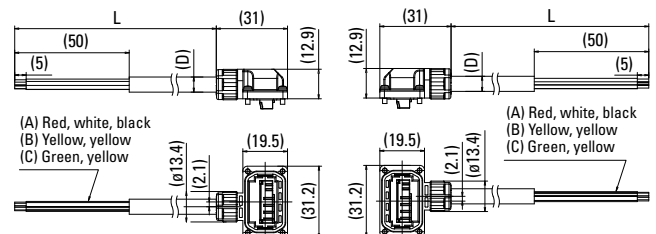

Cables

■ Servo motor power cable

The power supply for the holding brake needs to be provided by the customer

Front and rear cable exits are directed to the output shaft direction and the opposite direction, respectively.

100 mm sq.

L [m]	Model no. (w/o holding brake)		Model no. (w/ holding brake)			
1	GPPB0100S		GQPBO100SB			
3	GPPB0300S		GQPBO300SB			
5	GPPB0500S		GQPBO500SB			
(A) Power	14 AWG		14 AWG			
(B) Brake	20 AWG		20 AWG			
(C) Ground	Wire gauge	14 AWG		14 AWG		
	Terminal	N2-M4		N2-M4		
(D) Cable diameter	ø12.5		ø12.5			
Connection	Lead wire color	Motor signal name	Connector pin no.	Lead wire color	Motor signal name	Connector pin no.
	Red	U	A	Red	U	F
	White	V	B	White	V	I
	Black	W	C	Black	W	B
	Green	Ground	D	Green	Ground	E, D
	Yellow	—	—	Yellow	Brake	G, H

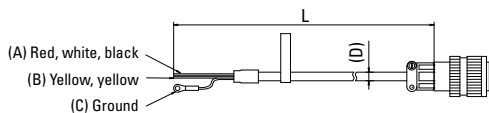

130 mm sq.

L [m]	Model no. (w/o holding brake)		Model no. (w/ holding brake)			
1	GRPB0100S		GRPB0100SB			
3	GRPB0300S		GRPB0300SB			
5	GRPB0500S		GRPB0500SB			
(A) Power	14 AWG		14 AWG			
(B) Brake	20 AWG		20 AWG			
(C) Ground	Wire gauge	14 AWG		14 AWG		
	Terminal	N2-M4		N2-M4		
(D) Cable diameter	ø12.5		ø12.5			
Connection	Lead wire color	Motor signal name	Connector pin no.	Lead wire color	Motor signal name	Connector pin no.
	Red	U	D	Red	U	D
	White	V	E	White	V	E
	Black	W	F	Black	W	F
	Green	Ground	G, H	Green	Ground	G, H
	Yellow	—	—	Yellow	Brake	A, B

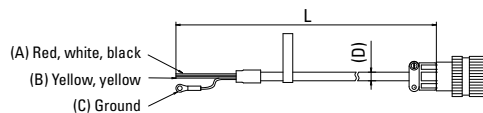

■ Servo motor encoder cable

40 to 86 mm sq.

Cable exit direction	L [m]	Model no.	
Front	1	GESF0100S	
Rear	1	GESR0100S	
Front	3	GESF0300S	
Rear	3	GESR0300S	
Front	5	GESF0500S	
Rear	5	GESR0500S	
Size	26 AWG		
(A) Cable diameter	ø5.1		
Connection	Lead wire color	Motor signal name	Connector pin no.
	Shielded	Ground	1
	Red	5V	2
	Black	SG	3
	White*	—	4
	Yellow*	—	5
	Brown	ES+	6
	Blue	ES-	7
	Green*	—	8
	Purple*	—	9

* Do not connect unused lead wires (white, yellow, green, or purple) to the servo amplifier.
Note: Contact us if the cable length is to be 10 m or longer.

Front cable exit

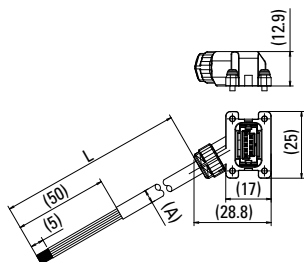

Rear cable exit

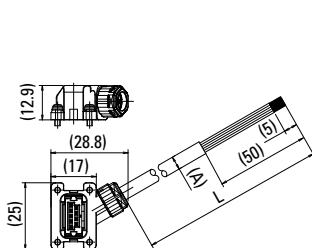

100 to 130 mm sq.

L [m]	Model no.		
1	RS-CA9-01-R		
3	RS-CA9-03-R		
5	RS-CA9-05-R		
(A) Cable diameter	ø6.7		
Connection	Motor side Straight plug Mfr. part no.: JN2DS10SL2-R (JAE) Pin no.	Amplifier side I/O connector Mfr. part no.: 54599-1016 (Molex Japan Co., Ltd.) Pin no.	Signal name
	1	7	ES+
	2	8	ES-
	3	—	—
	4	10	EBAT.*
	5	—	—
	6	—	—
	7	—	Ground
	8	9	EBAT+*
	9	1	5V
	10	2	SG

* Do not supply power to batteryless encoders.

Note: Contact us if the cable length is to be 25 m or longer.

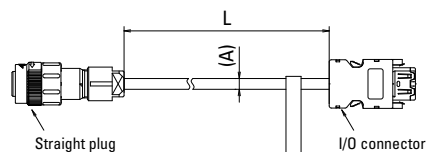

AC Reactors

It is recommended you install an AC reactor to the power supply input to suppress harmonic currents and correct the power factor.

Model no.	Compatible servo amplifier	Dimensions [Unit: mm]								Terminal Size	Mass [kg]
		W	W1	W2	H	D	D1	D2	d		
R-ACL-004	GADSA01 <input type="checkbox"/>	75	70	50	110	60	60	40	5	M4	0.8
	GADSA02 <input type="checkbox"/>										
	GADSE01 <input type="checkbox"/>										
R-ACL-01K	GADSA03 <input type="checkbox"/>	85	70	50	130	60	60	40		M4	1.2
R-ACL-02K	GADSA05 <input type="checkbox"/>	120	90	70	150	70	72	60		M4	1.8

Note: Connect an AC reactor to each servo amplifier.

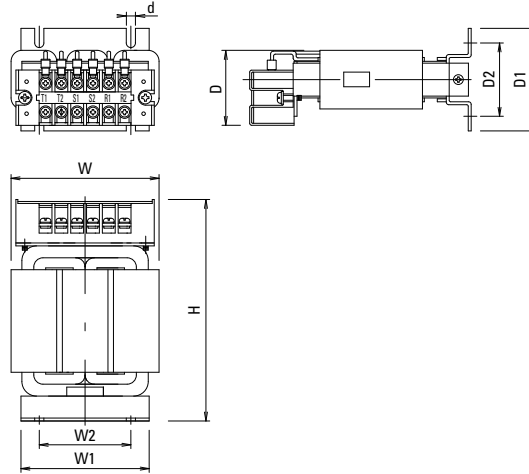

Analog Monitor [Unit in drawings: mm]

This is an analog monitor that is capable of displaying velocity waveforms and the like on an oscilloscope for the purpose of system tuning or maintenance.

Name	Details	Model no.
Monitor box	Monitor box unit 2 pcs of dedicated cables (on the right)	Q-MON-3

Name	Model no.
Dedicated cable	AL-00690525-01

Note: Power is supplied by the servo amplifier.

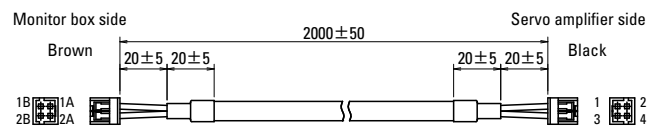
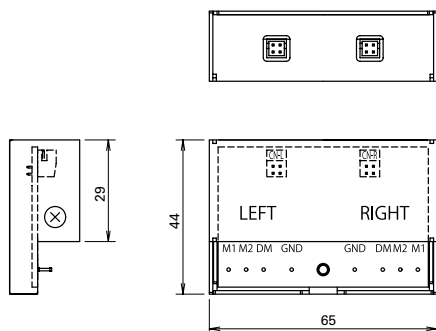

External Regenerative Resistor

[Unit in drawings: mm]

Model no.	Rated power [P _R]	Resistance	Mass
AL-R080W25B	80 W	25 Ω	0.19 kg

Thermostat detection temperature: 135 ±7°C (Normally-closed contact)

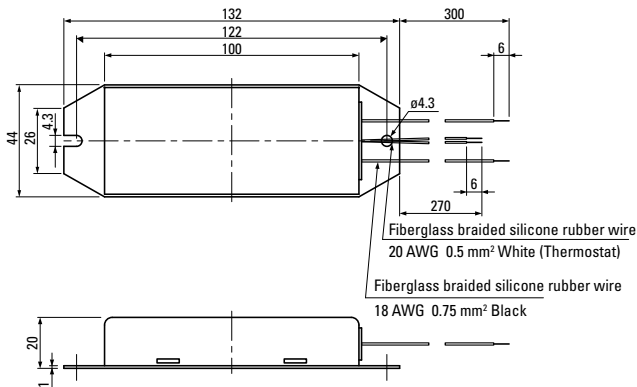

Model no.	Rated power [P _R]	Resistance	Mass
AL-R120W25B	120 W	25 Ω	0.24 kg

Thermostat detection temperature: 135 ±7°C (Normally-closed contact)

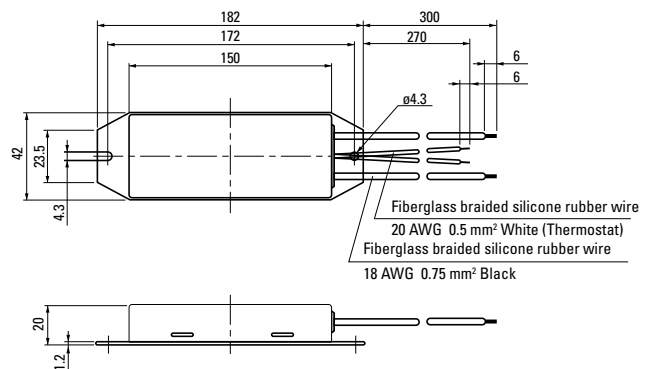

Model no.	Rated power [P _R]	Resistance	Mass
AL-R220W20B	220 W	20 Ω	0.44 kg
AL-R220W25B	220 W	25 Ω	0.44 kg
AL-R220W50B	220 W	50 Ω	0.44 kg

Thermostat detection temperature: 135 ±7°C (Normally-closed contact)

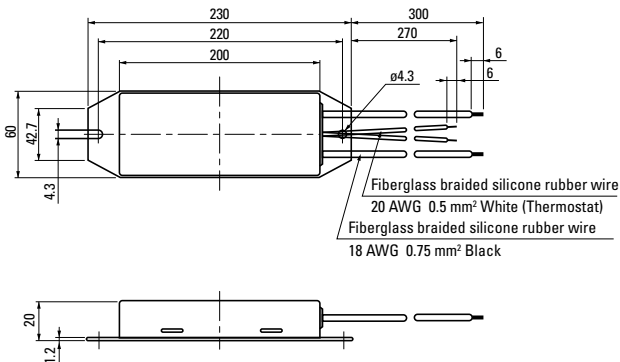

Model no.	Rated power [P _R]	Resistance	Mass
AL-R500W10B	500 W	10 Ω	1.4 kg
AL-R500W20B	500 W	20 Ω	1.4 kg
AL-R500W25B	500 W	25 Ω	1.4 kg

Thermostat detection temperature: 100 ±5°C (Normally-closed contact)

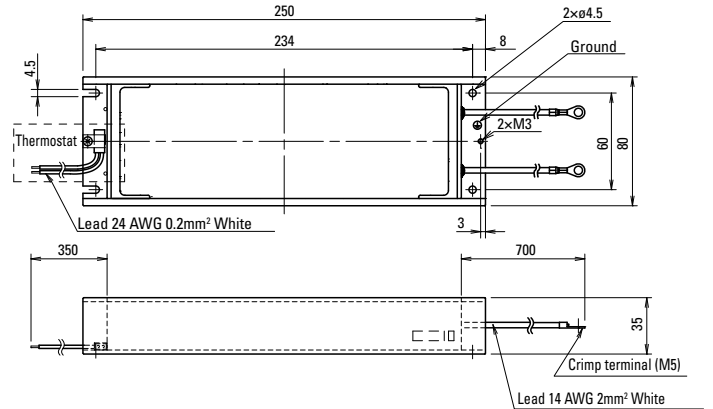

Front Mounting Brackets [Unit in drawings: mm]

Brackets for mounting the servo amplifier on the front (connector side).

Compatible servo amplifier	Model no.	Set items
10 A, 20 A, 30 A (GADS□01, 02, 03)	AL-01133484-01	Upper and lower mounting brackets: 1 each Mounting screws × 4 (M4 flat head, 8 mm)
50 A (GADSA05)	AL-00880391-01	Upper and lower mounting brackets: 1 each Mounting screws × 4 (M4 flat head, 8 mm)

Note 1: Trivalent chrome plating is used. (Surface color is silver-blue, and different from body color.)

Note 2: Cannot be used with battery box. (10 to 50 A)

AL-01133484-01
Upper bracket

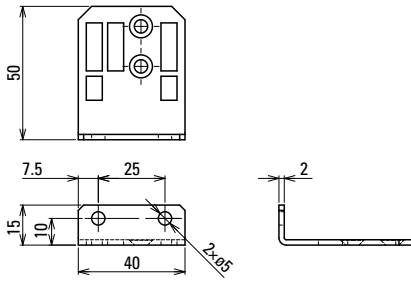

Lower bracket

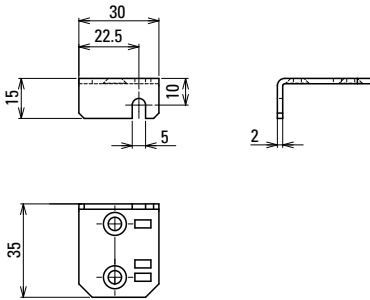

AL-00880391-01
Upper bracket

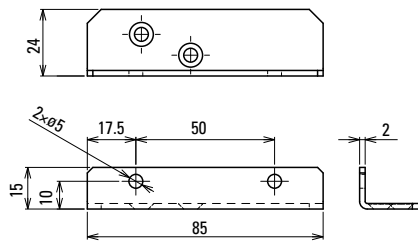

Lower bracket

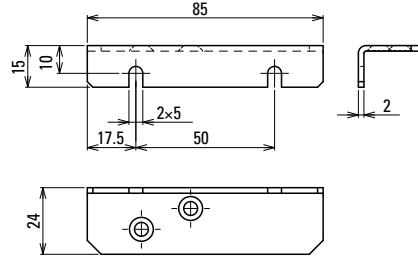

Mounting example

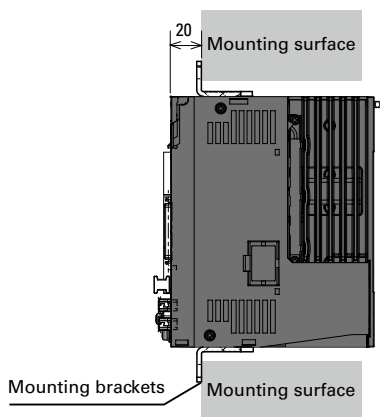

Mounting board dimensions example

10 A, 20 A

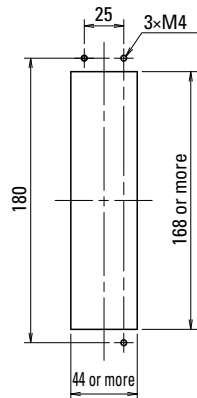

30 A

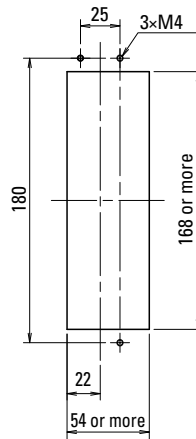

50 A

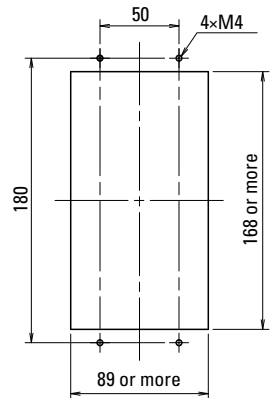

Replacement Models of Conventional Products

Servo motor

200 V Low-inertia servo motors

Motor flange size	Holding brake (24 VDC)	Rated output	Conventional SANMOTION R model no.	Rated output	SANMOTION G model no.
40 mm sq.	—	50 W	R1AA04005FX□03M	50 W	GAM1A4005F0X□□
	✓	50 W	R1AA04005FC□03M	50 W	GAM1A4005F0C□□
	—	100 W	R1AA04010FX□03M	100 W	GAM1A4010F0X□□
	✓	100 W	R1AA04010FC□03M	100 W	GAM1A4010F0C□□
60 mm sq.	—	200 W	R1AA06020FX□03M	200 W	GAM1A6020F0X□□
	✓	200 W	R1AA06020FC□03M	200 W	GAM1A6020F0C□□
	—	400 W	R1AA06040FX□03M	400 W	GAM1A6040F0X□□
	✓	400 W	R1AA06040FC□03M	400 W	GAM1A6040F0C□□
80 mm sq.	—	750 W	R1AA08075VX□03M	750 W	GAM1A8075V0X□□
	✓	750 W	R1AA08075VC□03M	750 W	GAM1A8075V0C□□
	—	750 W	R1AA08075FX□03M	750 W	GAM1A8075F0X□□
	✓	750 W	R1AA08075FC□03M	750 W	GAM1A8075F0C□□
100 mm sq.	—	1 kW	R1AA10100FX□00M	1 kW	GAM1AA100F0X□□
	✓	1 kW	R1AA10100FC□00M	1 kW	GAM1AA100F0C□□
	—	1 kW	R1AA10100HX□00M	1 kW	GAM1AA100H0X□□
	✓	1 kW	R1AA10100HC□00M	1 kW	GAM1AA100H0C□□
	—	1.5 kW	R1AA10150FX□00M	1.5 kW	GAM1AA150F0X□□
	✓	1.5 kW	R1AA10150FC□00M	1.5 kW	GAM1AA150F0C□□
	—	1.5 kW	R1AA10150HX□00M	1.5 kW	GAM1AA150H0X□□
	✓	1.5 kW	R1AA10150HC□00M	1.5 kW	GAM1AA150H0C□□

100 V Low-inertia servo motors

Motor flange size	Holding brake (24 VDC)	Rated output	Conventional SANMOTION R model no.	Rated output	SANMOTION G model no.
40 mm sq.	—	50 W	R1EA04005FX□03M	50 W	GAM1E4005F0X□□
	✓	50 W	R1EA04005FC□03M	50 W	GAM1E4005F0C□□
	—	100 W	R1EA04010FX□03M	100 W	GAM1E4010F0X□□
	✓	100 W	R1EA04010FC□03M	100 W	GAM1E4010F0C□□
60 mm sq.	—	200 W	R1EA06020FX□03M	200 W	GAM1E6020F0X□□
	✓	200 W	R1EA06020FC□03M	200 W	GAM1E6020F0C□□

100 V Medium-inertia servo motors

Motor flange size	Holding brake (24 VDC)	Rated output	Conventional SANMOTION R model no.	Rated output	SANMOTION G model no.
40 mm sq.	—	30 W	R2EA04003FX□03M	30 W	GAM2E4003F0X□□
	✓	30 W	R2EA04003FC□03M	30 W	GAM2E4003F0C□□
	—	50 W	R2EA04005FX□03M	50 W	GAM2E4005F0X□□
	✓	50 W	R2EA04005FC□03M	50 W	GAM2E4005F0C□□
	—	80 W	R2EA04008FX□03M	100 W	GAM2E4010F0X□□
	✓	80 W	R2EA04008FC□03M	100 W	GAM2E4010F0C□□
60 mm sq.	—	100 W	R2EA06010FX□03M	100 W	GAM2E6010F0X□□
	✓	100 W	R2EA06010FC□03M	100 W	GAM2E6010F0C□□
	—	200 W	R2EA06020FX□03M	200 W	GAM2E6020F0X□□
	✓	200 W	R2EA06020FC□03M	200 W	GAM2E6020F0C□□

200 V Medium-inertia servo motors

Motor flange size	Holding brake (24 VDC)	Rated output	Conventional SANMOTION R model no.	Rated output	SANMOTION G model no.
40 mm sq.	—	30 W	R2AA04003FX□03M	30 W	GAM2A4003F0X□□
	✓	30 W	R2AA04003FC□03M	30 W	GAM2A4003F0C□□
	—	50 W	R2AA04005FX□03M	50 W	GAM2A4005F0X□□
	✓	50 W	R2AA04005FC□03M	50 W	GAM2A4005F0C□□
	—	100 W	R2AA04010FX□03M	100 W	GAM2A4010F0X□□
	✓	90 W	R2AA04010FC□03M6	100W	GAM2A4010F0C□□
60 mm sq.	—	100 W	R2AA06010FX□03M	100 W	GAM2A6010F0X□□
	✓	100 W	R2AA06010FC□03M	100 W	GAM2A6010F0C□□
	—	200 W	R2AA06020FX□03M	200 W	GAM2A6020F0X□□
	✓	200 W	R2AA06020FC□03M	200 W	GAM2A6020F0C□□
	—	400 W	R2AA06040FX□03M	400 W	GAM2A6040F0X□□
	✓	360 W	R2AA06040FC□03M6	400W	GAM2A6040F0C□□
80 mm sq.	—	400 W	R2AA06040HX□03M	400 W	GAM2A6040F0X□□
	✓	360 W	R2AA06040HC□03M6	400W	GAM2A6040F0C□□
	—	200 W	R2AA08020FX□03M	200 W	GAM2A8020F0X□□
	✓	200 W	R2AA08020FC□03M	200 W	GAM2A8020F0C□□
	—	400 W	R2AA08040FX□03M	400 W	GAM2A8040F0X□□
	✓	400 W	R2AA08040FC□03M	400 W	GAM2A8040F0C□□
86 mm sq.	—	750 W	R2AA08075FX□03M	750 W	GAM2A8075F0X□□
	✓	750 W	R2AA08075FC□03M	750 W	GAM2A8075F0C□□
	—	750 W	R2AA08075FC□03M	750 W	GAM2A8075F0C□□
	✓	750 W	R2AA08075FC□03M	750 W	GAM2A8075F0C□□
	—	1 kW	R2AA08075FC□03M	750 W	GAM2A8075F0C□□
	✓	750 W	R2AA08075FC□03M	750 W	GAM2A8075F0C□□
100 mm sq.	—	1 kW	R2AA08075FC□03M	750 W	GAM2A8075F0C□□
	✓	750 W	R2AA08075FC□03M	750 W	GAM2A8075F0C□□
	—	750 W	R2AA08075FC□03M	750 W	GAM2A8075F0C□□
	✓	750 W	R2AA08075FC□03M	750 W	GAM2A8075F0C□□
	—	1 kW	R2AA10075FX□03M	750 W	GAM2AA075F0X□□
	✓	750 W	R2AA10075FC□03M	750 W	GAM2AA075F0C□□
130 mm sq.	—	1 kW	R2AA10100FX□03M	1 kW	GAM2AA100F0X□□
	✓	1 kW	R2AA10100FC□03M	1 kW	GAM2AA100F0C□□
	—	1.5 kW	R2AA10150HX□00M	1.5 kW	GAM2AA150H0X□□
	✓	1.5 kW	R2AA10150HC□00M	1.5 kW	GAM2AA150H0C□□
	—	550 W	R2AA13050HX□00M	550 W	GAM2AB055D0X□□
	✓	550 W	R2AA13050HC□00M	550 W	GAM2AB055D0C□□
130 mm sq.	—	550 W	R2AA13050DX□00M	550 W	GAM2AB055D0X□□
	✓	550 W	R2AA13050DC□00M	550 W	GAM2AB055D0C□□
	—	550 W	R2AA13050DX□00M	550 W	GAM2AB055D0X□□
	✓	550 W	R2AA13050DC□00M	550 W	GAM2AB055D0C□□
	—	1.2 kW	R2AA13120BX□00M	1.2 kW	GAM2AB120B0X□□
	✓	1.2 kW	R2AA13120BC□00M	1.2 kW	GAM2AB120B0C□□
	—	1.2 kW	R2AA13120LX□00M	1.2 kW	GAM2AB120H0X□□
	✓	1.2 kW	R2AA13120LC□00M	1.2 kW	GAM2AB120H0C□□
	—	1.2 kW	R2AA13120DX□00M	1.2 kW	GAM2AB120D0X□□
	✓	1.2 kW	R2AA13120DC□00M	1.2 kW	GAM2AB120D0C□□

Servo amplifier

200 V Analog/Pulse input type

GPO	Built-in regenerative resistor	STO function*	Amplifier capacity	Conventional SANMOTION R model no.	SANMOTION G model no.
Sinking type	-	-	10 A	RS3A01A0AL0	GADSA01LA00
	-	-	20 A	RS3A02A0AL0	GADSA02LA00
	-	-	30 A	RS3A03A0AL0	GADSA03LA00
	-	-	50 A	RS3A05A0AL0	GADSA05LA00
	-	✓	10 A	RS3A01A0AL2	GADSA01LA22
	-	✓	20 A	RS3A02A0AL2	GADSA02LA22
	-	✓	30 A	RS3A03A0AL2	GADSA03LA22
	-	✓	50 A	RS3A05A0AL2	GADSA05LA22
	✓	-	10 A	RS3A01A0AA0	GADSA01AA00
	✓	-	20 A	RS3A02A0AA0	GADSA02AA00
	✓	-	30 A	RS3A03A0AA0	GADSA03AA00
	✓	-	50 A	RS3A05A0AA0	GADSA05AA00
	✓	✓	10 A	RS3A01A0AA2	GADSA01AA22
	✓	✓	20 A	RS3A02A0AA2	GADSA02AA22
	✓	✓	30 A	RS3A03A0AA2	GADSA03AA22
	✓	✓	50 A	RS3A05A0AA2	GADSA05AA22
Sourcing type	-	-	10 A	RS3A01A0BL0	GADSA01LB00
	-	-	20 A	RS3A02A0BL0	GADSA02LB00
	-	-	30 A	RS3A03A0BL0	GADSA03LB00
	-	-	50 A	RS3A05A0BL0	GADSA05LB00
	-	✓	10 A	RS3A01A0BL2	GADSA01LB22
	-	✓	20 A	RS3A02A0BL2	GADSA02LB22
	-	✓	30 A	RS3A03A0BL2	GADSA03LB22
	-	✓	50 A	RS3A05A0BL2	GADSA05LB22
	✓	-	10 A	RS3A01A0BA0	GADSA01AB00
	✓	-	20 A	RS3A02A0BA0	GADSA02AB00
	✓	-	30 A	RS3A03A0BA0	GADSA03AB00
	✓	-	50 A	RS3A05A0BA0	GADSA05AB00
	✓	✓	10 A	RS3A01A0BA2	GADSA01AB22
	✓	✓	20 A	RS3A02A0BA2	GADSA02AB22
	✓	✓	30 A	RS3A03A0BA2	GADSA03AB22
	✓	✓	50 A	RS3A05A0BA2	GADSA05AB22

200 V EtherCAT interface type

Built-in regenerative resistor	STO function*	Amplifier capacity	Conventional SANMOTION R model no.	SANMOTION G model no.
-	✓	10 A	RS3A01A2HL4	GADSA01LH24
-	✓	20 A	RS3A02A2HL4	GADSA02LH24
-	✓	30 A	RS3A03A2HL4	GADSA03LH24
-	✓	50 A	RS3A05A2HL4	GADSA05LH24
✓	✓	10 A	RS3A01A2HA4	GADSA01AH24
✓	✓	20 A	RS3A02A2HA4	GADSA02AH24
✓	✓	30 A	RS3A03A2HA4	GADSA03AH24
✓	✓	50 A	RS3A05A2HA4	GADSA05AH24

100 V Analog/Pulse input type

GPO	Built-in regenerative resistor	STO function*	Amplifier capacity	Conventional SANMOTION R model no.	SANMOTION G model no.	
Sinking type	-	-	10 A	RS3E01A0AL0	GADSE01LA00	
	-	-	20 A	RS3E02A0AL0	GADSE02LA00	
	-	-	30 A	RS3E03A0AL0	GADSE03LA00	
	-	✓	10 A	RS3E01A0AL2	GADSE01LA22	
	-	✓	20 A	RS3E02A0AL2	GADSE02LA22	
	-	✓	30 A	RS3E03A0AL2	GADSE03LA22	
	✓	-	10 A	RS3E01A0AA0	GADSE01AA00	
	✓	-	20 A	RS3E02A0AA0	GADSE02AA00	
	✓	-	30 A	RS3E03A0AA0	GADSE03AA00	
	✓	✓	10 A	RS3E01A0AA2	GADSE01AA22	
	✓	✓	20 A	RS3E02A0AA2	GADSE02AA22	
	✓	✓	30 A	RS3E03A0AA2	GADSE03AA22	
	Sourcing type	-	-	10 A	RS3E01A0BL0	GADSE01LB00
		-	-	20 A	RS3E02A0BL0	GADSE02LB00
		-	-	30 A	RS3E03A0BL0	GADSE03LB00
		-	✓	10 A	RS3E01A0BL2	GADSE01LB22
-		✓	20 A	RS3E02A0BL2	GADSE02LB22	
-		✓	30 A	RS3E03A0BL2	GADSE03LB22	
✓		-	10 A	RS3E01A0BA0	GADSE01AB00	
✓		-	20 A	RS3E02A0BA0	GADSE02AB00	
✓		-	30 A	RS3E03A0BA0	GADSE03AB00	
✓		✓	10 A	RS3E01A0BA2	GADSE01AB22	
✓		✓	20 A	RS3E02A0BA2	GADSE02AB22	
✓		✓	30 A	RS3E03A0BA2	GADSE03AB22	

100 V EtherCAT interface type

Built-in regenerative resistor	STO function*	Amplifier capacity	Conventional SANMOTION R model no.	SANMOTION G model no.
-	✓	10 A	RS3E01A2HL4	GADSE01LH24
-	✓	20 A	RS3E02A2HL4	GADSE02LH24
-	✓	30 A	RS3E03A2HL4	GADSE03LH24
✓	✓	10 A	RS3E01A2HA4	GADSE01AH24
✓	✓	20 A	RS3E02A2HA4	GADSE02AH24
✓	✓	30 A	RS3E03A2HA4	GADSE03AH24

* Safe Torque Off (STO) is a safety function defined in IEC/EN 61800-5-2:2016.

Selection of Servo Motor Output (Rotary Motors)

This is a calculation method for deriving required servo motor output based on specifications of machines. In this instance an introduction on the procedure for the selection is provided primarily for instances where ball screw (horizontal) mechanism is involved.

Selection steps

1. Determine the motion profile

Determine the mechanism to use and the motion profile.

2. Calculate the axial load moment of inertia, J_L

Calculate the load moment of inertia about the motor axis based on the mechanism.

3. Calculate the moment of inertia of the motor's load, T_L

Calculate the load torque for the mechanism to use.

4. Provisional selection of servo motor output

Provisionally select a motor that meets the following conditions: the load moment of inertia (J_L) is 10 times or below the motor's rotor moment of inertia (J_M), and the load torque (T_L) is 80% or below ($T_R \times 0.8$) the motor's rated torque (T_R).

$$J_L \leq J_M \times 10$$

$$T_L \leq T_R \times 0.8$$

5. Calculate the acceleration/deceleration torque

Calculate the total torque required to accelerate/decelerate the system (motor and load) based on the motion profile.

6. Calculate actual torque

Calculate the required actual torque using a formula and the results of the previous steps.

7. Assessment

Check if the calculated acceleration and deceleration torques (T_a and T_b) are 80% or below the selected motor's peak torque at stall ($\leq T_p \times 0.8$) and the calculated actual torque (T_{rms}) is 80% or below the motor's rated torque ($\leq T_R \times 0.8$).

$$T_a \leq T_p \times 0.8$$

$$T_b \leq T_p \times 0.8$$

$$T_{rms} \leq T_R \times 0.8$$

If the selected motor does not meet the conditions above, then change the servo motor output and try one with a larger output.

8. Calculate the regenerative power

Calculate the regenerative power and select an external regenerative resistor if needed.

1. Determine the motion profile

First, determine the machine mechanism and required parameters such as the dimensions of components, positioning resolution, positioning time, and gear ratio. Make a motion profile for the determined drive in a graph with speed and time axes.

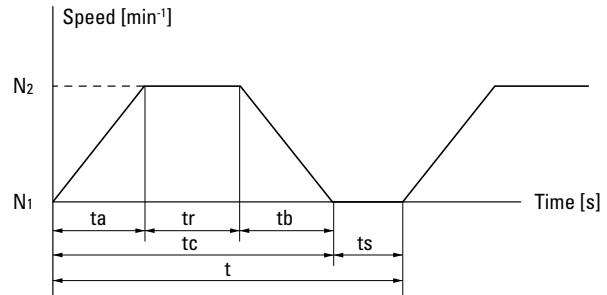

N_1 : Servo motor rotational speed before acceleration [min^{-1}]

N_2 : Servo motor rotational speed after acceleration [min^{-1}]

t_a = Time spent accelerating the load [s]

t_b = Time spent decelerating the load [s]

t_r = Time spent while motor is turning at constant speed [s]

t_s = Time spent while motor is at rest [s]

t = 1 cycle [s]

2. Calculate the axial load moment of inertia, J_L

Load moment of inertia is the quantity that expresses an object's resistance to change its state of rotational motion. The following formula is for calculating it in the case of a (horizontal) ball screw mechanism.

■ Moment of inertia of ball screw

$$J_{L1} = \left(\frac{1}{G}\right)^2 \times \frac{\pi \times \rho \times D^4 \times L}{32} \quad [\text{kg} \cdot \text{m}^2]$$

G: Gear ratio

ρ : Ball screw density [kg/m^3] (Iron: 7.8×10^3)

D: Ball screw diameter [m]

L: Ball screw length [m]

■ Moments of inertia of workpiece and table

$$J_{L2} = \left(\frac{1}{G}\right)^2 \times W \times \left(\frac{P}{2\pi}\right)^2 \quad [\text{kg} \cdot \text{m}^2]$$

G: Gear ratio

W: Workpiece mass + table mass [kg]

P: Ball screw pitch [m]

■ Axial moment of inertia of load

$$J_L = J_{L1} + J_{L2}$$

*The moments of inertia of the reduction gear and coupling are assumed to be small enough to be negligible.

3. Calculate the axial load torque, T_L

The formula for load torque converts forces exerted on the load due to friction and gravity into the rotational equivalent as reflected to the motor shaft by the lead screw. When activated, this torque always acts as the load.

The following formula is for calculating it in the case of a (horizontal) ball screw mechanism.

$$T_L = \frac{F + \mu W \times 9.8}{\eta} \times \frac{P}{2\pi} \times \frac{1}{G} \quad [\text{N} \cdot \text{m}]$$

F: External force [N]

η : Mechanical efficiency

μ : Friction coefficient

W: Workpiece mass + table mass [kg]

P: Ball screw lead [m]

G: Gear ratio

4. Provisional selection of servo motor output

Provisionally, select motors that satisfy the following 2 conditions.

- The load moment of inertia (J_L) calculated in step 2 is 10 times or below the motor's rotor moment of inertia ($J_M \times 10$)

$$J_L \leq J_M \times 10$$

- The load torque (T_L) calculated in step 3 is 80% or below the rated torque ($T_R \times 0.8$) of the motor

$$T_L \leq T_R \times 0.8$$

5. Calculate the acceleration/deceleration torque

The acceleration/deceleration torque is the torque required to accelerate or decelerate the motor and load.

- How to calculate acceleration torque (T_a)

$$T_a = \frac{2\pi(N_2 - N_1) \times (J_L + J_M)}{60 \times t_a} + T_L \quad [\text{N} \cdot \text{m}]$$

N_2 : Servo motor rotating velocity after acceleration [min^{-1}]

N_1 : Servo motor rotating velocity before acceleration [min^{-1}]

J_L : Load moment of inertia about the motor axis [$\text{kg} \cdot \text{m}^2$]

J_M : Rotor inertial moment of servo motor [$\text{kg} \cdot \text{m}^2$]

T_L : Axial load torque [N·m]

t_a : Acceleration time [s]

- Deriving deceleration torque (T_b)

$$T_b = \frac{2\pi(N_2 - N_1) \times (J_L + J_M)}{60 \times t_b} - T_L \quad [\text{N} \cdot \text{m}]$$

N_2 : Servo motor rotating velocity before deceleration [min^{-1}]

N_1 : Servo motor rotating velocity after deceleration [min^{-1}]

J_L : Load moment of inertia about the motor axis [$\text{kg} \cdot \text{m}^2$]

J_M : Rotor inertial moment of servo motor [$\text{kg} \cdot \text{m}^2$]

T_L : Axial load torque [N·m]

t_b : Deceleration time [s]

6. Calculate actual torque

The actual torque is a root mean square of the load torque, acceleration torque, and deceleration torque.

$$T_{\text{rms}} = \sqrt{\frac{(T_a^2 \times t_a) + (T_L^2 \times t_r) + (T_b^2 \times t_b)}{t}} \quad [\text{N} \cdot \text{m}]$$

7. Assessment

We use the following conditions for assessment.

- Load torque: $T_L \leq T_R \times 0.8$
(Load torque $\leq 80\%$ of the rated torque)
- Acceleration torque load factor $T_a \leq T_p \times 0.8$
(Acceleration torque $\leq 80\%$ of the peak torque at stall)
 T_p : Peak torque at stall
- Deceleration torque load factor $T_b \leq T_p \times 0.8$
(Deceleration torque $\leq 80\%$ of the peak torque at stall)
 T_p : Peak torque at stall
- Actual torque: $T_{\text{rms}} \leq T_R \times 0.8$
(Actual torque $\leq 80\%$ of the rated torque)
- Inertia moment ratio $J_L \leq J_M \times 10$
(Load moment of inertia ≥ 10 times or below the motor rotor moment of inertia)

Rise in motor temperature can be suppressed by keeping a large margin in torque load factor. The moment of inertia ratio can be more than 10 times, for example, for mechanisms that slowly rotate a table. We recommend that you conduct verifications using actual machines.

8. Calculate the regenerative power

Calculate the effective regenerative power (P_M) to determine the regenerative resistor to be used. The result of this calculation determines if a built-in regenerative resistor can be used or an external one is required.

- How to calculate effective regenerative power (P_M) for horizontal drive

First, calculate the regenerative energy.

$$E_M = E_{\text{hb}} = \frac{1}{2} \times N \times 3 \times K_{e\phi} \times \frac{T_b}{K_T} \times t_b - \left(\frac{T_b}{K_T} \right)^2 \times 3 \times R_\phi \times t_b$$

E_M : Regenerative energy during horizontal driving [J]

E_{hb} : Regenerative energy during deceleration [J]

$K_{e\phi}$: Phase voltage constant [$\text{V}_{\text{rms}}/\text{min}^{-1}$] (motor constant)

K_T : Torque constant [$\text{N} \cdot \text{m}/\text{A}_{\text{rms}}$] (motor constant)

N: Motor rotating velocity [min^{-1}]

R_ϕ : Phase resistance [Ω] (motor constant)

t_b : Deceleration time [s]

T_b : Torque from deceleration [N·m]

Calculate the regenerative power from regenerative energy.

$$P_M = \frac{E_M}{t}$$

P_M : Regenerative power [W]

E_M : Regenerative energy [J]

t: Cycle time [s]

- Selection of regenerative resistor

Select a regenerative resistor that satisfies the following conditions.

- For servo amplifiers with built-in regenerative resistor
Required regenerative power [P_M] < Maximum regenerative power that can be handled by a built-in regenerative resistor [P_R]
- External regenerative resistor
Required regenerative power [P_M] < Maximum regenerative power that can be handled by an external regenerative resistor [P_{R0}]

Note that our servo amplifiers either come with and without built-in regenerative resistors for absorbing regenerative power. Make a selection carefully.

Selection Materials by Mechanism

Typical mechanism examples and required selection criteria are shown below. Provide us with these information when consulting us for selection.

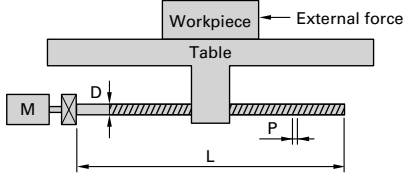
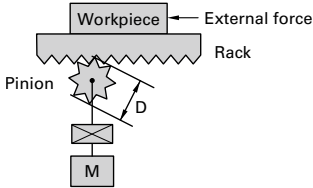
Ball screw			Rack & Pinion				
							
External force	F	<input type="text"/>	N	External force	F	<input type="text"/>	N
Workpiece + table mass	W	<input type="text"/>	kg	Workpiece + rack mass	W	<input type="text"/>	kg
Ball screw diameter	D	<input type="text"/>	m	Pinion diameter	D	<input type="text"/>	m
Ball screw length	L	<input type="text"/>	m	Pinion thickness	L	<input type="text"/>	m
Ball screw pitch	P	<input type="text"/>	m	Pinion density	ρ	<input type="text"/>	kg/m ³
Ball screw density	ρ	<input type="text"/>	kg/m ³	Friction coefficient	μ	<input type="text"/>	
Friction coefficient	μ	<input type="text"/>		Gear ratio *	G	<input type="text"/>	
Gear ratio *	G	<input type="text"/>		Mechanical efficiency	η	<input type="text"/>	
Mechanical efficiency	η	<input type="text"/>				<input type="text"/>	

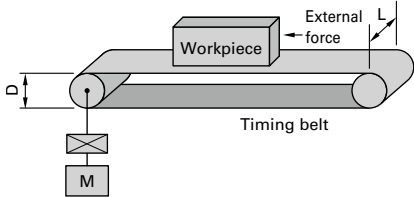
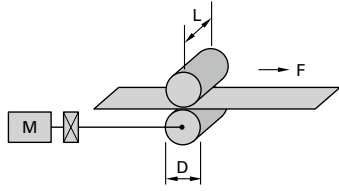
Belt drive			Roll feed				
							
External force	F	<input type="text"/>	N	Sheet tension	F	<input type="text"/>	N
Workpiece + belt mass	W	<input type="text"/>	kg	Roll diameter	D	<input type="text"/>	m
Pulley diameter	D	<input type="text"/>	m	Roll width	L	<input type="text"/>	m
Pulley width	L	<input type="text"/>	m	Roll density	ρ	<input type="text"/>	kg/m ³
Pulley density	ρ	<input type="text"/>	kg/m ³	Gear ratio *	G	<input type="text"/>	
Gear ratio *	G	<input type="text"/>		Mechanical efficiency	η	<input type="text"/>	
Mechanical efficiency	η	<input type="text"/>				<input type="text"/>	

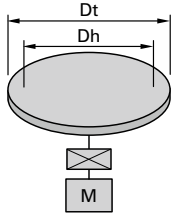
Rotary indexing table			
			
Table mass	W	<input type="text"/>	kg
Table diameter	Dt	<input type="text"/>	m
Table support diameter	Dh	<input type="text"/>	m
Friction coefficient of table support	μ	<input type="text"/>	
Gear ratio *	G	<input type="text"/>	
Mechanical efficiency	η	<input type="text"/>	

* Calculation of gear ratio (G)

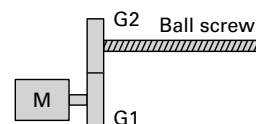





$$G = \frac{\text{Number of screw threads (G2)}}{\text{Number of motor gear teeth (G1)}}$$

Standards Conformity

■ All servo motor (rotary motor) models Contact us for linear servo motors.

Standards conformity		Standard code	Logo
Classification	Category		
UL/cUL standards	—	UL 1004-1, UL 1004-6 (File No. E179832)	
CE marking for EU Directive	Low Voltage Directive (2014/35/EU)	IEC 60034-1, EN 60034-1 IEC 60034-5, EN 60034-5	
	RoHS Directive (2011/65/EU as amended by (EU)2015/863)	EN 63000:2018 IEC 63000:2018	
UKCA marking for Great Britain (UK Conformity Assessed Marking)	Electrical Equipment (Safety) Regulations 2016	IEC 60034-1, EN 60034-1 IEC 60034-5, EN 60034-5	
	RoHS Regulations 2012	EN 63000:2018 IEC 63000:2018	

■ All servo amplifier models

Safety Standards		Standard code	Logo
Classification	Category		
UL/cUL standards	—	UL 61800-5-1 (File No. E179775)	
KC Mark (Korea Certification Mark)	—	KS C 9610-6-2 KS C 9610-6-4	
CE marking for EU Directive	Low Voltage Directive (2014/35/EU)	IEC 61800-5-1, EN 61800-5-1	
	Electromagnetic Compatibility Directive (2014/30/EU)	EN 61000-6-2 IEC 61800-3, EN 61800-3	
	RoHS Directive (2011/65/EU as amended by (EU)2015/863)	EN 63000:2018 IEC 63000:2018	
UKCA marking for Great Britain (UK Conformity Assessed Marking)	Electrical Equipment (Safety) Regulations 2016	IEC 61800-5-1, EN 61800-5-1	
	Electromagnetic Compatibility Regulations 2016	EN 61000-6-2 IEC 61800-3, EN 61800-3	
	RoHS Regulations 2012	EN 63000:2018 IEC 63000:2018	

■ Servo amplifier with STO Model no.: GADS□□□□□□2, GADS□□□□□□4

(Scheduled to obtain functional safety certifications in October 2022)

Standards conformity			Standard code	Logo	
Classification	Category				
Third party certification (TÜV SÜD)	Electrical safety	Low Voltage Directive (2014/35/EU)	IEC 61800-5-1, EN 61800-5-1		
	Functional safety	Generic Functional safety			IEC 61508, EN 61508
		Functional safety under Machinery Directive (2006/42/EC)			IEC 62061, EN 62061 EN ISO 13849-1 / AC: 2015
		Functional safety for PDS under Machinery Directive (2006/42/EC)			IEC 61800-5-2, EN 61800-5-2
	EMC	Electromagnetic Compatibility Directive (2014/30/EU)			EN 61000-6-2 IEC 61800-3, EN 61800-3
		Functional safety EMC			IEC 61326-3-1, EN 61326-3-1 EN 61000-6-7

■ Servo amplifier without STO Model no.: GADS□□□□□□0 Options

Standards conformity			Standard code	Logo
Classification	Category			
Third party certification (TÜV SÜD)	Electrical safety	Low Voltage Directive (2014/35/EU)	IEC 61800-5-1, EN 61800-5-1	
	EMC	Electromagnetic Compatibility Directive (2014/30/EU)		

Motor Protection Rating

The protection ratings of our servo motors comply with IEC standards (IEC 60034-5). The standard states that the liquid used for testing should be fresh (pure) water, and liquids other than water such as oil are not included in the test conditions.

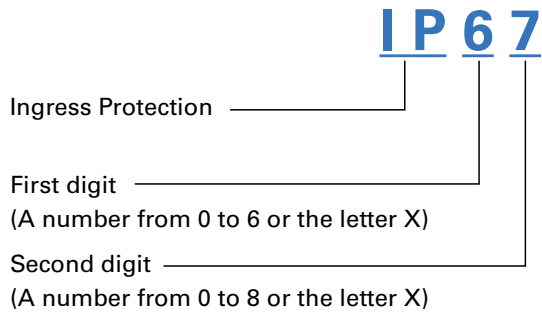

The degree of protection (IP code) is defined by IEC (International Electrotechnical Commission) 60529 "Degrees of Protection Provided by Enclosures (IP Code)" (IEC 60529)

First digit	Description	Definition
0	No protection	—
1	Protection against solid objects > 50 mm	A spherical 50 mm diameter solid probe shall not completely penetrate
2	Protection against solid objects > 12.5 mm	A spherical 12.5 mm diameter solid probe shall not completely penetrate
3	Protection against solid objects > 2.5 mm	A spherical 2.5 mm diameter solid probe shall not penetrate at all
4	Protection against solid objects > 1 mm	A spherical 1 mm diameter solid probe shall not penetrate at all
5	Protection against a level of dust that could hinder operation or impair safety	Although it is impossible to completely prevent the penetration of dust, there should be no intrusion of an amount of dust that could impede the prescribed operation and safety of the electrical equipment
6	Complete protection against dust	Completely protected against dust

Second digit	Description	Definition
0	No protection	—
1	Protected against vertically falling drops of water	Vertically dripping water shall have no harmful effect.
2	Protected against vertically falling drops of water even if inclined within 15 degrees	Vertically dripping water shall have no harmful effect when the enclosure is tilted at an angle up to 15° from the vertical.
3	Protected against spraying water	Water falling as a spray at any angle up to 60° from the vertical shall have no harmful effect.
4	Protected against splashing water	Water splashing against the enclosure from any direction shall have no harmful effect.
5	Protected against water jets	Water projected by a nozzle against enclosure from any direction shall have no harmful effects.
6	Protected against powerful water jets	Water projected in powerful jets against the enclosure from any direction shall have no harmful effects.
7	Protected against temporary immersion in water	Ingress of water in harmful quantity shall not be possible when the enclosure is immersed in water under defined conditions of pressure and time.
8	Protected against submersion in water	The equipment is suitable for continuous immersion in water under conditions which shall be specified by the manufacturer. The test conditions are expected to be greater than the depth requirements for IPx7, and other environmental effects may be added.

Note 1: The standard states that the liquid used for testing should be fresh (pure) water, and liquids other than water such as oil are not included in the test conditions.

Separate evaluation is necessary when used in environments subjected to non-water liquids, e.g., where machine tool cutting oil is present. Our servo motors have a proven track record of optional customization for machine tool applications, so please contact us as necessary.

Note 2: The ratings for water ingress (second digit) are not cumulative beyond IPX6. A device that is compliant with IPX7 (covering immersion in water) is not necessarily compliant with IPX5 or IPX6 (covering exposure to water jets). Select a protection rating suitable for your environment.

Safety Precautions

The products featured in this catalog are designed for use with general industrial machinery. Pay sufficient attention to the following.

- Read the included Instruction Manual carefully before installing, assembling, and using the product for proper use. The Instruction Manual is available for download from our website.
- Do not modify or alter the product in any way.
- Contact your point of sale or a properly licensed technician for installation or maintenance service of the product.
- Consult us when using the motor for the following uses, as these require special considerations for installation, operations, maintenance, and management such as redundancy and emergency power generators.
 - **Use in medical equipment or other devices that may directly affect people's lives or cause bodily injury.**
 - **Use in transportation systems or transport-related equipment such as trains or elevators, that may affect people's lives or cause bodily injury.**
 - **Systems or equipment that may have a major impact on society or on the public.**
 - **Special applications related to aviation and space, nuclear power, electric power, submarine repeaters, etc.**

For applications subject to vibration such as in vehicles or ships, please contact us in advance. Please read and understand all of the equipment knowledge, safety information, and precautions before use.

Warning Labels on Products

Products bear the following Warning Labels to indicate the situations as below, depending on the model.



This label is attached in the vicinity of high-voltage portions such as charging or cover-protected parts, to indicate locations with risk of electric shock.



This label is attached in the vicinity of grounding terminals to indicate that grounding is required.

Safety Alert Symbols

■ Warning symbol

 **DANGER** Denotes immediate hazards that will cause severe bodily injury or death if not avoided.

 **WARNING** Denotes immediate hazards which will probably cause severe bodily injury or death if not avoided.

 **CAUTION** Denotes hazards which could cause bodily injury and product or property damage if not avoided.

Notice Denotes hazards which could cause product or property damage without bodily injury if not avoided.

Note that even items with a  symbol could potentially lead to serious outcomes, depending on the situation. They all indicate important situations, so be sure to observe them.

■ Prohibited/Mandatory symbol

 **PROHIBITED** Indicates actions that must not be taken.

 **MANDATORY** Indicates actions that must be taken.

Storage

Notice

- Avoid storing products in environments exposed to rain or water drops or with hazardous gas or liquid. Failure to follow this may cause product failures.
- Store products where they are not exposed to direct sunlight, within the specified temperature and humidity ranges of -20 to +65°C, below 95% RH (non-condensing). Failure to follow this may cause product failures.
- When you use servo amplifiers after a long-term storage (3 years or longer), contact us. The capacitance of electrolytic capacitors can decrease through long-term storage, which may cause malfunctions.
- When you use servo motors after a long-term storage (3 years or longer), contact us. Checking on bearings and motor holding brakes will be needed.

Transportation

CAUTION

- Do not lift the motor by the cable, connector, motor output shaft, or terminal box when transporting. Failure to follow this may cause injury, product failure, or damage.
- Transport the motor with great care to avoid the risk of it falling or tipping over. Failure to follow this may cause injury.
- Follow the instructions displayed on the package box and avoid excessively stacking boxes. Failure to follow this may cause injury or product failures.
- Use the included eyebolts for transporting servo motors alone. Do not use them for transporting machines in which servo motors are used. Failure to follow this may cause product failures.

Installation

WARNING

- Do not use products in flammable or explosive environments. Failure to follow this may cause fire.
- Mount the motor to incombustible materials such as metals. Failure to follow this may cause fire.
- Use a servo motor in an environment where the motor's protection rating is sufficient. Failure to follow this may cause electric shock, fire, or product failures.
- Avoid installing the motor in locations exposed to water, cutting oil, oil mist, iron powder, or metal chips. Failure to follow this may cause electric shock, fire, or product failures.
- Make sure that oil, flammable foreign objects, cables, or metal fragments do not get inside the motor. Failure to follow this may cause fire.
- Install an emergency stop circuit to the outside of equipment to turn the power off immediately whenever needed. Failure to follow this may cause injury or fire.
- Be sure to connect a molded case circuit breaker (MCCB) or fuse between the power supply and the servo amplifier's main circuit power supply terminals for overcurrent protection. Failure to follow this may cause electric shock or fire.

CAUTION

- Install safety devices such as circuit breakers in case of short-circuiting of external wiring. Failure to follow this may cause fire.
- Unpack the box with the right side up. Failure to follow this may cause injury.
- Do not stand on the servo motor or place heavy objects on top of it. Failure to follow this may cause injury.
- Install the motor with great care to avoid the risk of it falling or tipping over. Use eyebolts if supplied. Failure to follow this may cause injury.
- Ensure that the servo motor is securely mounted to equipment. Doing otherwise may cause it to fly out while operating.
- Do not touch the servo motor output shaft (especially the keyway and gears) with your bare hand. Failure to follow this may cause injury.
- Make sure that the output shaft of the servo motor and the mating machine are well aligned. Failure to follow this may cause injury or product failures.
- The motor holding brake cannot be used as a dynamic brake to secure the safety of machinery. Install a stopping device to machinery to ensure safety. Failure to do so may result in injury.
- When using servo motors in vertical axes, install safety devices (such as an external brake) to prevent a moving part from falling in the event of an alarm. Failure to follow this may cause injury.
- Designing a safety system that uses the STO function must be done by individuals who have safety standard expertise and have sufficiently understood the descriptions of section 4.5 "Safe Torque Off" in the User's Manual Laws/Regulations Conformity Guidelines. Failure to follow this may cause injury.

Notice

- Keep the ambient temperature of the installed servo amplifier/motor within the specified operating temperature/humidity range. Failure to follow this may cause product failures.
- Make sure to install products in the specified mounting orientation. Failure to follow this may cause product failures.
- The load applied to the servo motor output shaft should be less than the allow-

able load. Failure to follow this may cause product failures.

- Do not strike the motor shaft with a hammer when installing or removing a coupling to the shaft. Failure to follow this may cause product failures.
- Do not drop products or subject them to excessive shock of any kind. Failure to follow this may cause product failures.
- Do not block the air inlet or outlet. Failure to follow this may cause product failures.
- Keep a specified distance between the servo amplifier and the inner surface of the control board or other devices. Failure to follow this may cause product failures.
- Prepare an external protective circuit to the amplifier to cut off the main circuit power in the event of an alarm. Failure to follow this may cause secondary damage.
- For anti-collision devices, use ones that can sufficiently withstand the maximum output of the system. Failure to follow this may cause product failures.

Wiring

WARNING

- Be sure to ground the protective grounding terminal (Ⓧ) of a servo amplifier to the machine or control board. The grounding terminal of a servo motor must be connected to the protective grounding terminal (Ⓧ) of the amplifier. Failure to follow this may cause electric shock or fire.
- Do not work on wiring, maintenance servicing, or inspection with power on. After turning off the power, wait at least 15 minutes and check that the CHARGE LED (red) for the main circuit power supply turns off before working. Failure to follow this may cause electric shock.
- Do not connect commercial power supply or ground to the U, V, and W terminals of servo motors. Failure to follow this may cause fire.
- Install safety devices such as circuit breakers in case of short-circuiting of external wiring. Failure to follow this may cause fire.
- Do not damage, apply excessive stresses, put heavy things on, or tuck down cables. Failure to follow this may cause electric shock or fire.
- Use the right power supply (number of phases, voltage, frequency, VAC/VDC) for the motor. Failure to follow this may cause fire.

Notice

- Use servo amplifiers and servo motors in specified combinations. Failure to follow this may cause product failures.
- Perform wiring correctly and securely. Failure to follow this may cause product failures.
- Power cables, including the main circuit power cable and motor power cable of the servo amplifier, and signal cables must not be tied together or passed through the same duct or conduit. Also, the servo motor power cable and encoder cable must not be tied together or passed through the same duct or conduit. Failure to follow this may cause faulty operation.
- When connecting an inductive load such as a relay to the control output signal of the servo amplifier, be sure to connect a surge absorber diode. Ensure that the polarity of the diode is correct. Failure to follow this may cause product failures.
- Check that the power supply for servo motor holding brake and cooling fan meet specifications (number of phases, voltage, frequency, VAC/VDC). Failure to follow this may cause product failures.

Operation

WARNING

- Never touch inside of servo amplifiers with hands. Failure to follow this may cause electric shock.
- Never touch the rotating part of servo motors during operation. Failure to follow this may cause injury.
- Test-run a servo motor with the motor position fixed and isolated from machine systems. Install the motor to the machine system only after the test is done. Failure to follow this may cause injury.
- Never touch terminals and connectors while electricity is supplied. Failure to follow this may cause electric shock.

CAUTION

- Do not apply a magnetic field to the encoder cover of the servo motor. (Do not attach magnets such as magnet stands to the encoder cover.) Failure to follow this may cause product failures.
- While power is on or for some time after power-off, the servo amplifier heat-sink, regenerative resistor, external resistor for dynamic brake, and servo motor may be hot. Take safety measures such as covering to prevent them from being touched accidentally, if required. If safety measures cannot be taken, attach a high-temperature caution label. Failure to follow this may cause burns.
- Do not make extreme setting changes on servo parameters as doing so may result in unstable operations. Failure to follow this may cause injury.
- Stay away from equipment when power is restored after an outage or a momentary outage because the system may restart suddenly. (Make settings on equipment to secure safety on such occasions.) Failure to follow this may cause injury.
- Stop operations immediately when an emergency occurs. When an alarm is activated, remove the cause and ensure safety before resuming operations. Failure to follow this may cause injury.

- Never plug or unplug connectors while power is on (hot swapping) as the resulting surge voltage may cause electronic component malfunctions. Failure to follow this may cause electric shock or product damage.

Notice

- The holding brake built into servo motors must not be used for dynamic braking. Failure to follow this may cause product failures.
- Do not apply static electricity or excessively high voltage to servo motor encoder cables. Failure to follow this may cause product failures.
- When inertia moment or rotational speed is high, do not use exceeding regenerative resistor cable capacity by instantaneous regenerative power. Failure to follow this may cause product failures.
- Do not drive the servo motor by external power when the dynamic brake is activated due to power shutdown or alarm. Failure to follow this may cause product failures.
- Do not turn the power on and off frequently that the frequency exceeds 30 times/day or 5 times/hour. Failure to follow this may cause product failures.
- The surge absorber for the servo motor's holding brake relay prolongs the brake delay time. Therefore, program a sequence taking the delay time into account. Failure to follow this may cause product failures. Refer to User's Manual "2. Servo Motor" for holding delay time.

Maintenance and Inspection

WARNING

- Never attempt to disassemble, repair, or alter this product in any way. Doing so might result in electric shock.

Guideline for Suppressing Harmonics

Harmonic current generated by equipment such as servo amplifiers can potentially have adverse impact on other power consumers, if it flows out. Therefore, "Guideline for Suppressing Harmonics by Customers Receiving High Voltage or Special High Voltage" is published by the Ministry of International Trade and Industry (current Ministry of Economy).

Servo amplifiers used by specific power consumers fall under the category of "harmonic wave generating devices".

Consumers to whom the guideline is applied must determine if harmonic suppression measures are necessary based on the guideline and take measures for keeping harmonic emission within the limit specified by the power contract.

Even for consumers to whom the guideline is not applied, it is recommended they take harmonic suppression measures in order to avoid troubles due to the harmonics.

Our servo amplifiers fall under the circuit classification in Table 1 of the "Guideline for Suppressing Harmonics".

Refer to the following document for calculation method of harmonic currents. "How to Calculate Harmonic Current of Servo Amplifiers for Specific Power Consumers" (JEM-TR225) by Japan Electrical Manufacturers' Association

Table 1

Servo amplifier model no.	Power supply	Circuit classification	Circuit type	Conversion coefficient Ki		
GADS□01□□□□ GADS□02□□□□ GADS□03□□□□ GADS□05□□□□	3-phase power supply Without AC reactor	3	3-phase bridge (Smoothing capacitor)	3-1	6-pulse converter without reactor	K31 = 3.4
	3-phase power supply With AC reactor			3-2	6-pulse converter with reactor (AC side)	
	Single-phase power supply Without AC reactor	4	Single-phase bridge (Smoothing capacitor, full-wave rectification)	4-3	Without reactor	K43 = 2.9
	Single-phase power supply With AC reactor			4-4	With reactor (AC side)	

References

- "Guideline for Suppressing Harmonics by Customers Receiving High Voltage or Special High Voltage" (September, 1994) by Ministry of International Trade and Industry (current Ministry of Economy, Trade and Industry)
- "Technical Guidelines for Suppressing Harmonics" (JEAG 9702-2018) by The Japan Electric Association
- "Measures for Suppressing Servo Amplifier and General-purpose Inverter Harmonics" (April 2022), by Japan Electrical Manufacturers' Association
- "How to Calculate Harmonic Current of Servo Amplifiers for Specific Power Consumers" (JEM-TR225) by Japan Electrical Manufacturers' Association
- "Guideline for Suppressing Servo Amplifier (input current 20 A or less) Harmonics" (JEM-TR227) by Japan Electrical Manufacturers' Association

CAUTION

- Do not use servo amplifiers or servo motors that have failed, damaged, or burnt out. Failure to follow this may cause fire.

Notice

- Parts and components used in servo amplifiers (such as electrolytic capacitors, cooling fans, lithium batteries for encoders, fuses, and relays) deteriorate by aging. Considering the standard replacement period, replace these parts and components with new ones for preventive maintenance. Contact us for details. Failure to follow this may cause product failures.
- Do not perform measurements of insulation resistance or dielectric voltage of the servo amplifier or servo motor. Failure to follow this may cause product failures.

PROHIBITED

- Do not remove the nameplate.

Disposal

MANDATORY

- Dispose of servo amplifiers and servo motors as industrial waste.

Determine whether or not any harmonics suppression measures are required on the converter (AC-DC converter) side if the servo amplifier has a DC input power supply of DC type.

When harmonic suppression measures are necessary for the servo amplifier, connect a harmonic suppression reactor. Contact us for the harmonic suppression reactor.

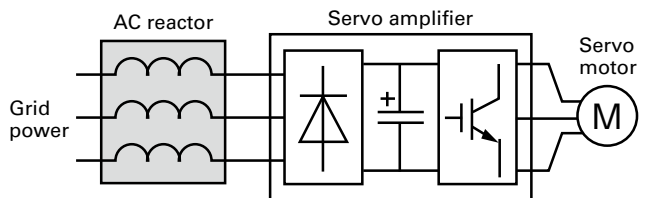

EtherCAT® is a registered trademark and patented technology, licensed by Beckhoff Automation GmbH, Germany.

SANYO DENKI CO., LTD. 3-33-1 Minami-Otsuka, Toshima-ku, Tokyo 170-8451, Japan TEL: +81 3 5927 1020 <https://www.sanyodenki.com/>

The names of companies and/or their products specified in this document are the trade names, and/or trademarks and/or registered trademarks of such respective companies.

San Ace, SANUPS, and SANMOTION are registered trademarks of SANYO DENKI CO., LTD.

Specifications are subject to change without notice.

CATALOG No. S1062B002 '23.6